

OPERATION MANUAL



WHITEMAN
MODELS
LD6
LD6SL
HYDRAULIC RIDE-ON TROWEL
(VANGUARD 23 HP GASOLINE ENGINE)

Revision #6 (02/13/23)

To find the latest revision of this publication or associated parts manual, visit our website at:
www.multiquip.com



THIS MANUAL MUST ACCOMPANY THE EQUIPMENT AT ALL TIMES.

PN: 45640

SUPPLIER'S DECLARATION OF CONFORMITY 47 CFR § 2.1077 COMPLIANCE INFORMATION

UNIQUE IDENTIFIER: 45573

RESPONSIBLE PARTY – U.S. Contact Information

MULTIQUIP INC.

6141 Katella Ave. Suite 200

Cypress, CA 90630

Phone: +1 (310)-537-3700

+1 (800)-421-1244

<https://www.multiquip.com>

FCC COMPLIANCE STATEMENT:

This device complies with Part 15 of the FCC Rules. Operation is subject to the following two conditions:

- (1) This device may not cause harmful interference, and
- (2) this device must accept any interference received, including interference that may cause undesired operation

PROPOSITION 65 WARNING



SILICOSIS/RESPIRATORY WARNINGS

⚠️ WARNING



SILICOSIS WARNING

Grinding/cutting/drilling of masonry, concrete, metal and other materials with silica in their composition may give off dust or mists containing crystalline silica. Silica is a basic component of sand, quartz, brick clay, granite and numerous other minerals and rocks. Repeated and/or substantial inhalation of airborne crystalline silica can cause serious or fatal respiratory diseases, including silicosis. In addition, California and some other authorities have listed respirable crystalline silica as a substance known to cause cancer. When cutting such materials, always follow the respiratory precautions mentioned above.

⚠️ WARNING



RESPIRATORY HAZARDS

Grinding/cutting/drilling of masonry, concrete, metal and other materials can generate dust, mists and fumes containing chemicals known to cause serious or fatal injury or illness, such as respiratory disease, cancer, birth defects or other reproductive harm. If you are unfamiliar with the risks associated with the particular process and/or material being cut or the composition of the tool being used, review the material safety data sheet and/or consult your employer, the material manufacturer/supplier, governmental agencies such as OSHA and NIOSH and other sources on hazardous materials. California and some other authorities, for instance, have published lists of substances known to cause cancer, reproductive toxicity, or other harmful effects.

Control dust, mist and fumes at the source where possible. In this regard use good work practices and follow the recommendations of the manufacturers or suppliers, OSHA/NIOSH, and occupational and trade associations. Water should be used for dust suppression when wet cutting is feasible. When the hazards from inhalation of dust, mists and fumes cannot be eliminated, the operator and any bystanders should always wear a respirator approved by NIOSH/MSHA for the materials being used.

TABLE OF CONTENTS

LD6/LD6SL Ride-On Power Trowel

FCC Compliance Statement.....	2
Proposition 65 Warning	3
Silicosis/Respiratory Warnings	4
Table of Contents.....	5
Training Checklist	6
Daily Pre-Operation Checklist	7
Safety Information	8–14
Lifting and Transporting	15–18
Specifications	19
Dimensions.....	20
General Information.....	21
Components (Trowel)	22–24
Components (Engine).....	25
Setup	26
Inspection	27–28
Operation.....	29–33
Maintenance	34–44
Troubleshooting	46–48
Electrical Component Locator	49
Electrical Wiring Diagram	50–51
Electrical Wiring Diagram (Pitch Kit).....	52
Electrical Wiring Diagram (Optional Light Kit)	53
Electrical Wiring Diagram (Optional Spray Kit).....	54
Electrical Wiring Diagram (Power and Ground).....	55
Hydraulic Component Locator	56
Hydraulic System Diagram.....	57

NOTICE

Specifications are subject to change without notice.

TRAINING CHECKLIST

Training Checklist			
No.	Description	OK?	Date
1	Read operation manual completely		
2	Machine layout, location of components, checking of engine and hydraulic oil levels		
3	Fuel system, refueling procedure		
4	Operation of spray and lights (options)		
5	Operation of controls (machine not running)		
6	Safety controls, safety stop switch operation		
7	Emergency stop procedures		
8	Startup of machine		
9	Maintaining a hover		
10	Maneuvering		
11	Pitching		
12	Concrete finishing techniques		
13	Shutdown of machine		
14	Lifting of machine (lift loops)		
15	Machine transport and storage		

DAILY PRE-OPERATION CHECKLIST

Daily Pre-Operation Checklist		✓	✓	✓	✓	✓	✓
1	Engine oil level						
2	Hydraulic oil level						
3	Condition of blades						
4	Blade pitch operation						
5	Safety stop switch operation						
6	Steering control operation						

SAFETY INFORMATION

DO NOT operate or service the equipment before reading the entire manual. Safety precautions should be followed at all times when operating this equipment. Failure to read and understand the safety messages and operating instructions could result in injury to yourself and others.



SAFETY MESSAGES

The four safety messages shown below will inform you about potential hazards that could injure you or others. The safety messages specifically address the level of exposure to the operator and are preceded by one of four words: **DANGER**, **WARNING**, **CAUTION** or **NOTICE**.

SAFETY SYMBOLS

⚠ DANGER

Indicates a hazardous situation which, if not avoided, **WILL** result in **DEATH** or **SERIOUS INJURY**.

⚠ WARNING

Indicates a hazardous situation which, if not avoided, **COULD** result in **DEATH** or **SERIOUS INJURY**.

⚠ CAUTION

Indicates a hazardous situation which, if not avoided, **COULD** result in **MINOR** or **MODERATE INJURY**.

NOTICE

Addresses practices not related to personal injury.

Potential hazards associated with the operation of this equipment will be referenced with hazard symbols which may appear throughout this manual in conjunction with safety messages.







Symbol	Safety Hazard
	Lethal exhaust gas hazards
	Explosive fuel hazards
	Burn hazards
	Rotating parts hazards
	Pressurized fluid hazards
	Hydraulic fluid hazards

SAFETY INFORMATION

SAFETY DECALS

Decals associated with the safe operation of this equipment are defined below.

DECAL	DEFINITION
	<p>CAUTION Burn Hazard HOT PARTS can burn skin. DO NOT touch hot parts. Allow machine sufficient amount of time to cool before performing maintenance.</p>
	<p>WARNING Lifting/Crush Hazard NEVER allow any person to stand underneath the trowel while lifting. DO NOT lift trowel with pans attached. ALWAYS make sure handle is securely attached.</p>
	<p>WARNING Cancer and Reproductive Harm This equipment may contain or produce chemicals and substances known to cause cancer, birth defects and other reproductive harm. ALWAYS work in a well-ventilated area and ALWAYS wear approved safety equipment.</p>
	<p>DANGER Guard Hazard DO NOT operate equipment with guards removed. Serious bodily injury could result.</p>
	<p>DANGER Training This machine to be operated by qualified personnel only. Ask for training as needed.</p>
	<p>DANGER Inhalation Hazard DO NOT use this equipment in an enclosed area. The engine used with this equipment emits harmful levels of carbon monoxide which can cause severe bodily harm — even death!</p>
	<p>DANGER Rotating Blade Hazard Keep hands, fingers, and feet clear of engine fan blades and guard rings. Moving parts can cut. DO NOT remove guards. Stop engine before servicing.</p>
	<p>WARNING Fire, Smoking, Explosion, Inhalation Hazard DO NOT smoke or light matches near this equipment. This equipment contains highly flammable fuel. DO NOT use this equipment in an enclosed area.</p>

DECAL	DEFINITION
	<p>NOTICE Radio Noise This product complies with Canadian ICES-002.</p>
	<p>NOTICE Read Manual To avoid injury, you must read and understand the operator's manual before using this machine.</p>
	<p>NOTICE Protective Clothing ALWAYS wear appropriate clothing when operating the trowel.</p>
	<p>NOTICE Lifting Location Attach a suitable lifting device here to lift the unit.</p>
	<p>NOTICE Tie-Down Location ALWAYS tie-down equipment during transport.</p>
	<p>NOISE LEVEL Indicates value of the sound power of the equipment measured at operator's seat.</p>
	<p>UNLEADED GASOLINE The engine used in this equipment runs on unleaded gasoline.</p>

SAFETY INFORMATION

GENERAL SAFETY

CAUTION

- **NEVER** operate this equipment without proper protective clothing, shatterproof glasses, respiratory protection, hearing protection, steel-toed boots and other protective devices required by the job or city and state regulations.



- Avoid wearing jewelry or loose-fitting clothes that may snag on the controls or moving parts, as this can cause serious injury.

- **NEVER** operate this equipment when on medication or when not feeling well due to fatigue or illness. 

- **NEVER** operate this equipment under the influence of drugs or alcohol.



- **ALWAYS** clear the work area of any debris, tools, etc. that would constitute a hazard while the equipment is in operation.

- No one other than the operator is to be in the working area when the equipment is in operation.

- **NEVER** use the equipment for any purpose other than its intended purposes or applications.

NOTICE

- This equipment should only be operated by trained and qualified personnel 18 years of age and older.
- Whenever necessary, replace nameplate, operation and safety decals when they become difficult to read.
- Manufacturer does not assume responsibility for any accident due to equipment modifications. Unauthorized equipment modification will void all warranties.
- **NEVER** use accessories or attachments that are not recommended by Multiquip for this equipment. Damage to the equipment and/or injury to the user may result.
- **ALWAYS** know the location of the nearest **fire extinguisher**. 
- **ALWAYS** know the location of the nearest **first aid kit**. 
- **ALWAYS** know the location of the nearest phone or **keep a phone on the job site**. Also, know the phone numbers of the nearest **ambulance**, **doctor** and **fire department**. This information will be invaluable in the case of an emergency.

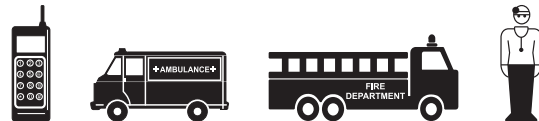

SAFETY INFORMATION

TROWEL SAFETY

DANGER

- Engine fuel exhaust gases contain poisonous carbon monoxide. This gas is colorless and odorless, and can cause **DEATH** if inhaled.
- The engine of this equipment requires an adequate free flow of cooling air. **NEVER** operate this equipment in any enclosed or narrow area where the free flow of air is restricted. If the air flow is restricted it will cause injury to people and property and serious damage to the equipment or engine.



- **NEVER** operate the equipment in an explosive atmosphere or near combustible materials. An explosion or fire could result causing **severe bodily harm or even death**.



WARNING

- **NEVER** use your hand to find hydraulic leaks. Use a piece of wood or cardboard. Hydraulic fluid injected into the skin must be treated by a knowledgeable physician immediately or **severe injury or death** can occur.



- **ALWAYS** keep clear of rotating or moving parts while operating the trowel.



- **NEVER** disconnect any **emergency or safety devices**. These devices are intended for operator safety. Disconnection of these devices can cause **severe injury, bodily harm or even death**. Disconnection of any of these devices will void all warranties.

CAUTION

- **NEVER** allow passengers or riders on the trowel during operation.
- **NEVER** lubricate components or attempt service on a running machine.
- **NEVER** place your feet or hands inside the guard rings while starting or operating this equipment.

NOTICE

- **ALWAYS** keep the machine in proper running condition.
- Fix damage to the machine and replace any broken parts immediately.
- **ALWAYS** store equipment properly when it is not being used. Equipment should be stored in a clean, dry location out of the reach of children and unauthorized personnel.
- A safety manual for operating and maintenance personnel of concrete power trowels produced by the Association of Equipment Manufacturers (AEM) can be obtained for a fee by ordering through their website at www.aem.org.

Order FORM PT-160

ENGINE SAFETY

WARNING

- **NEVER** place hands or fingers inside the engine compartment while the engine is running.
- **NEVER** operate the engine with heat shields or guards removed.
- **DO NOT** remove the engine oil drain plug while the engine is hot. Hot oil will gush out of the oil tank and severely scald any persons in the general area of the trowel.

CAUTION

- **NEVER** touch the hot exhaust manifold, muffler or cylinder. Allow these parts to cool before servicing the equipment.



SAFETY INFORMATION

NOTICE

- **DO NOT** allow the engine to run unattended at a high idle position for longer than 5 minutes. The hydraulic system will overheat if the engine idles for too long without spinning the rotors.
- **NEVER** run the engine without an air filter or with a dirty air filter. Severe engine damage may occur. Service the air filter frequently to prevent engine malfunction.
- **NEVER** tamper with the factory settings of the engine or engine governor. Damage to the engine or equipment can result if operating in speed ranges above the maximum allowable.



FUEL SAFETY

DANGER

- **NEVER** start the engine near spilled fuel or combustible fluids. Fuel is extremely flammable and its vapors can cause an **explosion** if ignited.
- **ALWAYS** refuel in a well-ventilated area, away from sparks and open flames.
- **ALWAYS** use extreme caution when working with **flammable** liquids.
- **DO NOT** fill the fuel tank while the engine is running or hot.
- **NEVER** overfill the fuel tank, as spilled fuel could ignite if it comes into contact with hot engine parts or sparks from the ignition system.
- Store fuel in appropriate containers, in well-ventilated areas and away from sparks and flames.
- **NEVER** use fuel as a cleaning agent.
- **NEVER** smoke around or near the equipment. **Fire or explosion** could result from fuel vapors or if fuel is spilled on a hot engine.



BATTERY SAFETY

DANGER

- **DO NOT** drop the battery. There is a possibility that the battery will explode.
- **NEVER** expose the battery to open flames, sparks, cigarettes, etc. The battery contains combustible gases and liquids. If these gases and liquids come into contact with a flame or spark, an **explosion** could occur.



WARNING

- **ALWAYS** wear safety glasses when handling the battery to avoid eye irritation. The battery contains acids that can cause injury to the eyes and skin.
- Use well-insulated gloves when picking up the battery.
- **ALWAYS** keep the battery charged. If the battery is not charged, combustible gas will build up.
- **DO NOT** charge the battery if frozen. The battery can **explode**. When frozen, warm the battery to at least 61°F (16°C).
- **ALWAYS** recharge the battery in a well-ventilated environment to avoid the risk of a dangerous concentration of combustible gases.
- If the battery liquid (dilute sulfuric acid) comes into contact with **clothing or skin**, rinse skin or clothing immediately with plenty of water.
- If the battery liquid (dilute sulfuric acid) comes into contact with **eyes**, rinse eyes immediately with plenty of water and contact the nearest doctor or hospital to seek medical attention.



CAUTION

- **ALWAYS** disconnect the **NEGATIVE** battery terminal before performing service on the equipment.
- **ALWAYS** keep battery cables in good, working condition. Repair or replace all worn cables.

SAFETY INFORMATION

TRANSPORTING SAFETY

⚠ CAUTION

- **DO NOT** allow any person or animal to stand underneath the equipment while it is being lifted.
- Ride-on trowels are very heavy and awkward to move around. Use proper heavy lifting procedures. **NEVER** attempt to lift the trowel by the guard rings.
- **NEVER** lift the trowel with the operator on the machine.



NOTICE

- Two lifting straps should have a minimum lifting capacity of 850 pounds (386 kg) and the lifting gear must be capable of lifting at least this amount.
- **NEVER** transport the trowel with float pans attached unless safety catches are used and are specifically cleared for such transport by the manufacturer.
- **NEVER** hoist the trowel more than three feet off the ground with float pans attached.
- Before lifting, make sure that the lift loops are not damaged.
- **ALWAYS** make sure the crane or lifting device has been properly secured to the lift loops of the equipment.
- **ALWAYS** shut down the engine before transporting.
- **DO NOT** lift the equipment while the engine is running.
- Tighten the fuel tank cap securely and close the fuel cock to prevent fuel from spilling.
- **NEVER** lift the trowel to unnecessary heights.
- **ALWAYS** tie down equipment during transport by securing the equipment with straps. Inspect the straps to make sure they are not frayed or damaged.

TOWING SAFETY

⚠ CAUTION

- Check with your local, county or state safety towing regulations, in addition to meeting **Department of Transportation (DOT) safety towing regulations**, before towing the trowel.



ENVIRONMENTAL SAFETY/DECOMMISSIONING

NOTICE

Decommissioning is a controlled process used to safely retire a piece of equipment that is no longer serviceable. If the equipment poses an unacceptable and unrepairable safety risk due to wear or damage or is no longer cost effective to maintain (beyond life-cycle reliability) and is to be decommissioned (demolition and dismantlement), be sure to follow the rules below.

- **NEVER** pour waste or oil directly onto the ground, down a drain, or into any water source.
- Contact your country's Department of Public Works or a recycling agency in your area and arrange for proper disposal of any electrical components, waste, or oil associated with this equipment.
- When the life cycle of this equipment is over, remove the battery and bring it to an appropriate facility for lead reclamation. Use safety precautions when handling batteries that contain sulfuric acid.
- When the life cycle of this equipment is over, it is recommended that the trowel frame and all other metal parts be sent to a recycling center.



Metal recycling involves the collection of metal from discarded products and its transformation into raw materials to use in manufacturing new products.

Recyclers and manufacturers alike promote the process of recycling metal. Using a metal recycling center promotes energy cost savings.

EMISSIONS INFORMATION

NOTICE

The gasoline engine used in this equipment has been designed to reduce harmful levels of carbon monoxide (CO), hydrocarbons (HC) and nitrogen oxides (NOx) contained in exhaust emissions.

This engine has been certified to meet US EPA evaporative emissions requirements in the installed configuration.

Attempts to modify or make adjustments to the engine emission system by unauthorized personnel without proper training could damage the equipment or create an unsafe condition.

Additionally, modifying the fuel system may adversely affect evaporative emissions, resulting in fines or other penalties.

Emission Control Label

The emission control label is an integral part of the emission system and is strictly regulated.

The label must remain with the engine for its entire life.

If a replacement emission label is needed, please contact your authorized engine distributor.

LIFTING AND TRANSPORTING

WORK SAFELY!

WARNING



Failure to comply with these lifting instructions may result in **sling failure** and **severe personal injury or death**.

Only **qualified personnel** with proper training should perform this procedure. Follow all rigging and lifting safety rules when performing this procedure.

LIFTING SAFETY

CAUTION

- **NEVER** allow any person to stand underneath the equipment while lifting.
- Ride-on trowels are very heavy and awkward to move around. Use proper heavy lifting procedures and **DO NOT** attempt to lift the trowel by the guard rings.
- **NEVER** lift the trowel with the operator on the machine.

NOTICE

- **NEVER** hoist the trowel more than three feet off of the ground with float pans attached.
- Before lifting, make sure that the lift loops are not damaged.
- **ALWAYS** make sure any lifting device has been properly secured to the lift loops of the trowel.
- **DO NOT** lift the trowel to unnecessary heights.
- **ALWAYS** shut down the engine before transporting.
- Tighten the fuel tank cap securely and close the fuel cock to prevent fuel from spilling.

SLING INSPECTION

Inspect the lifting slings provided with your trowel (Figure 1) **before each use**. If replacement slings are needed, refer to the parts manual included with your trowel for part numbers, and order from your Multiquip parts dealer or importer.

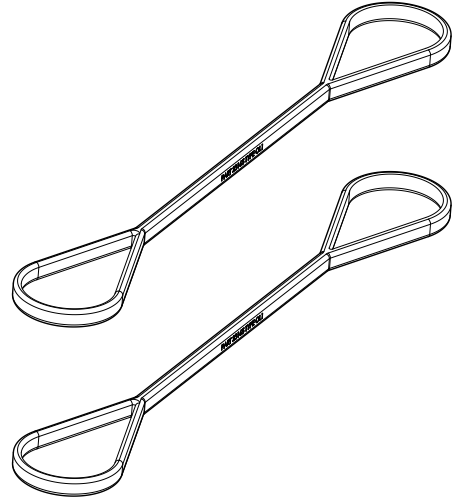
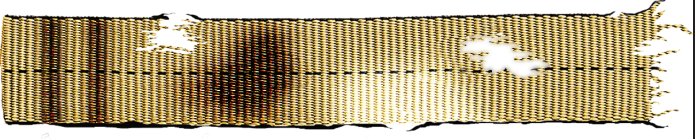

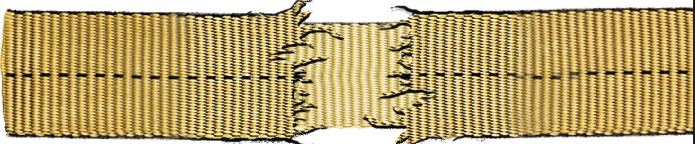
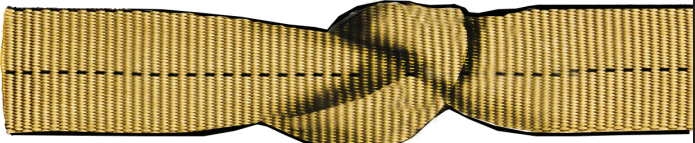

Figure 1. Lifting Slings

LIFTING AND TRANSPORTING

The Occupational Safety and Health Administration (OSHA) Regulation 29 CFR Part 1926.251 (e)(8)—*Removal from service* requires that the slings be inspected prior to each use, and **removed from service immediately** if any of the following conditions are found:

<ul style="list-style-type: none">■ Holes, tears, cuts, or snags■ Embedded particles■ Abrasive wear that exposes core fibers	
<ul style="list-style-type: none">■ Missing or unreadable Rated Capacity tags■ Melting, charring, weld spatter, or chemical burns	
<ul style="list-style-type: none">■ Broken or worn stitching that exposes the core fibers	
<ul style="list-style-type: none">■ Knots	
<ul style="list-style-type: none">■ Any other condition which may cause doubt as to the strength of the sling	

LIFTING AND TRANSPORTING

LIFTING PROCEDURE

The correct lifting slings (Figure 1) have been supplied with your trowel, in accordance to its weight per Occupational Safety and Health Administration (OSHA) Regulation 29 CFR Part 1926.251—*Rigging equipment for material handling*.

WARNING

ALWAYS inspect the lifting slings **before** each use.

NOTICE

MAKE SURE the forklift has adequate lifting capacity to lift the trowel.

The proper sling hitch method for connecting the lifting slings to the ride-on trowel is the **choker hitch**. The rated capacity of the slings for this method is indicated on the sling labels. **DO NOT** use any other type of sling hitch!

1. Secure the lifting slings to the lift loops (Figure 2) located to the left and right of the operator's seat.

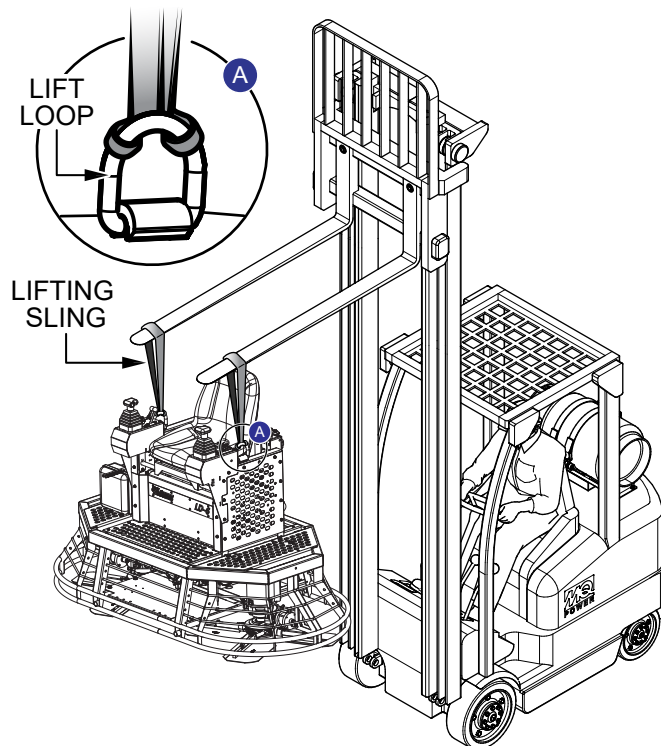

Figure 2. Lifting the Trowel

2. Insert forklift forks through the loops at the ends of the lifting slings. Keep the slings as close to vertical as possible.

3. If the choke angle (Figure 3) is 120 degrees or less, the lifting strength of the slings must be de-rated as shown in Table 1, in accordance with ASME Standard B30.9.

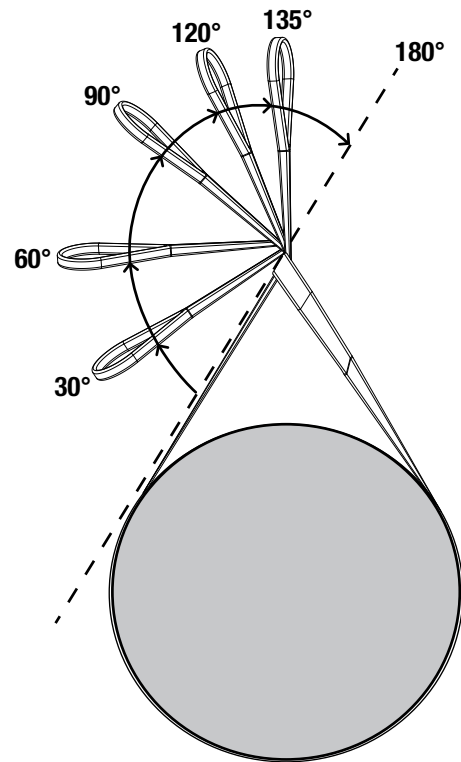

Figure 3. Choke Angle

Table 1. Choker Hitch Sling Capacity	
Choke Angle (°)	Rated Capacity (%)
Over 120	100
90–120	87
60–89	74
30–59	62
0–29	49

LIFTING AND TRANSPORTING

TRANSPORTING THE TROWEL

After the trowel has been lifted onto a flatbed truck, do the following:

1. Locate the tie-down symbols (Figure 4) on each side of the trowel.

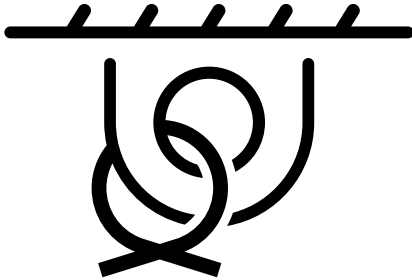

Figure 4. Tie-Down Symbol

2. Attach suitable tie-down straps to the locations marked by the tie-down symbols. Be sure to connect the tie-down strap hooks directly to the trowel as shown in Figure 5. **DO NOT** wrap the tie-downs around the frame as shown in Figure 6.

NOTICE

Use tie-downs with flat hooks or U-hooks only.

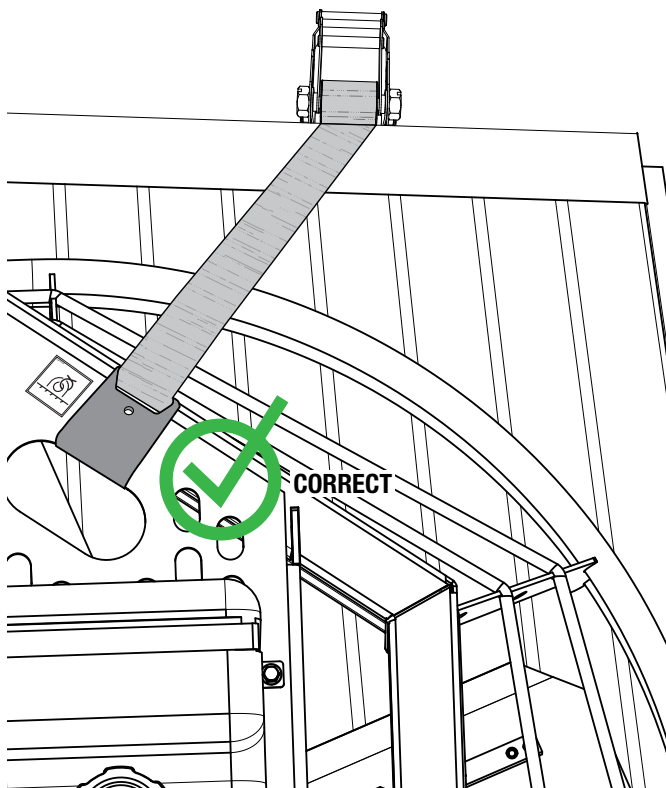

Figure 5. Tie-Down Method (Correct)

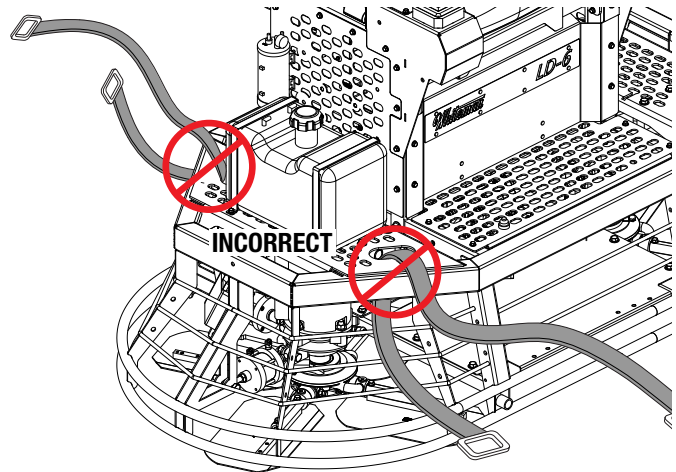

Figure 6. Tie-Down Method (Incorrect)

3. Secure the trowel to a flatbed with the tie-down straps, making sure they are properly tied to prevent movement of the trowel during transport.

SPECIFICATIONS

Table 2. LD6 Trowel Specifications

Operating Weight	850 lb. (386 kg)
Shipping Weight	960 lb. (435 kg)
Maximum Rotor Speed	140 rpm
Blades per Rotor	4
Path Width	75 in. (1,905 mm)
Hydraulic Oil Capacity	2.2 gal. (10 liters)
Hydraulic Oil Type	Parker DuraClean ISO 46

Table 3. Vanguard Engine Specifications

Model	Vanguard 3864
Type	Small block, V-twin, horizontal shaft, air-cooled, OHV, gasoline engine
Number of Cylinders	2
Displacement	38.3 CID (627 cm ³)
Compression Ratio	8.4:1
Bore × Stroke	2.97 × 2.76 in. (75 × 70 mm)
Maximum Output	23 hp (17 kW @ 3,600 rpm)
Oil Capacity with Filter	48 oz. (1.4 liters)
Oil Type	High-quality detergent oil classified "For service SF, SG, SH, SJ" or higher.
Spark Plug Type	Resistor
Spark Plug Gap	0.030 in. (0.76 mm)
Fuel Type	Minimum 87 octane unleaded gasoline
Fuel Capacity	4 gallons (15 liters)

Table 4. LD6 Noise and Vibration Emissions

Guaranteed ISO 11201:2010 Based Sound Pressure Level at Operator Station in dB(A)	TBD
Guaranteed ISO 3744:2010 Based Sound Power Level in dB(A)	TBD
Whole Body Vibration per ISO 2631-1:1997 in m/s ² $\Sigma A(8)$	0.05

NOTES:

1. Sound pressure and power levels are "A" weighted measures per ISO 226:2003 (ANSI S1.4-1981). They are measured using operating conditions of the machine which generate the most repeatable but highest values of the sound levels. Under normal circumstances, the sound level will vary depending on the condition of the material being worked upon.
2. The vibration level indicated is the vector sum of the RMS (root mean square) values of amplitudes on each axis, standardized to an 8-hour exposure period, and obtained using operating conditions of the machine that generate the most repeatable but highest values in accordance with the applicable standards for the machine.
3. Per EU Directive 2002/44/EC, the daily exposure action value for whole body vibration is 0.5 m/s² $\Sigma A(8)$. The daily exposure limit value is 1.15 m/s² $\Sigma A(8)$.

DIMENSIONS

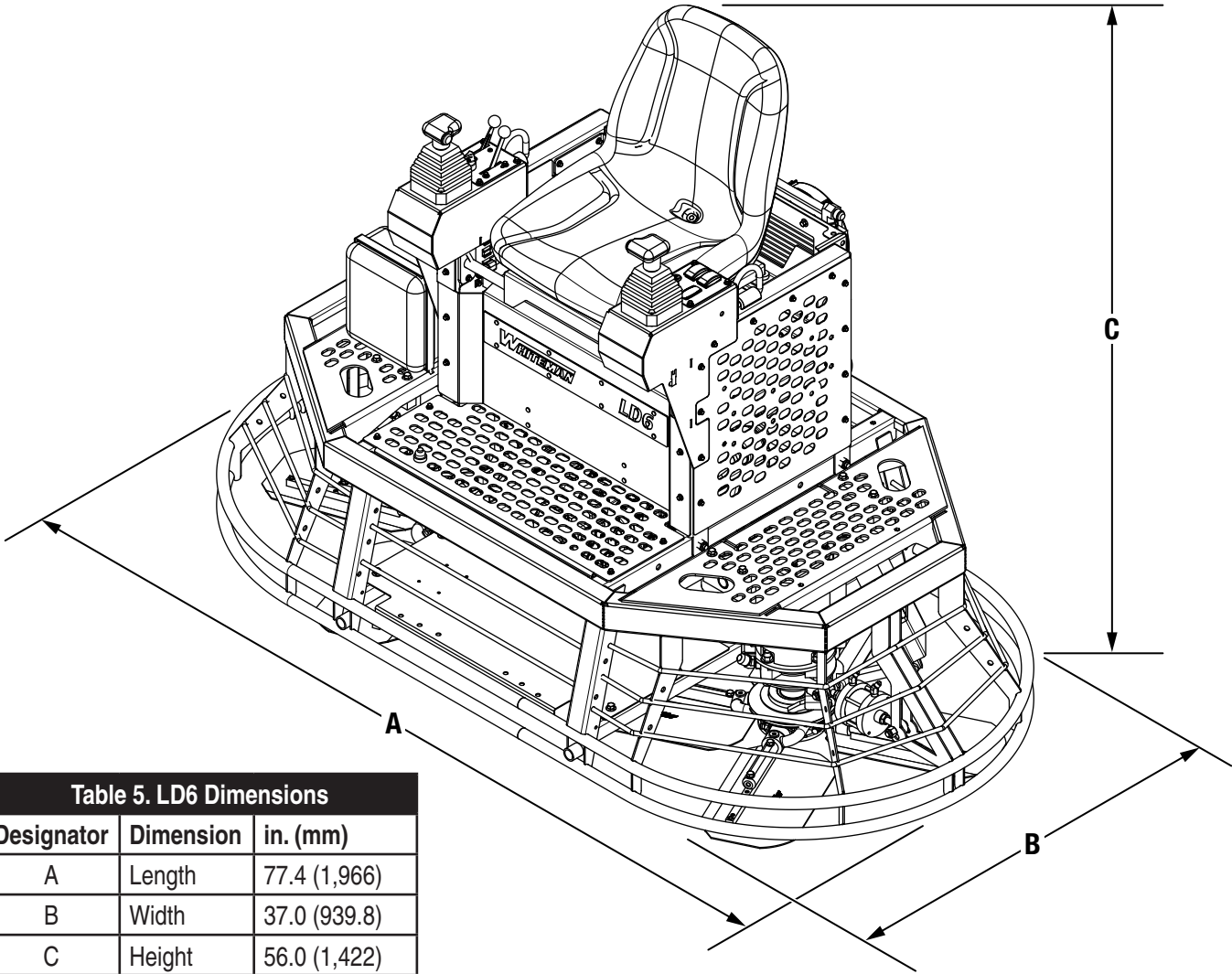

Table 5. LD6 Dimensions		
Designator	Dimension	in. (mm)
A	Length	77.4 (1,966)
B	Width	37.0 (939.8)
C	Height	56.0 (1,422)

Figure 7. LD6 Dimensions

GENERAL INFORMATION

INTENDED USE

Operate the LD6 ride-on power trowel, tools, and components in accordance with the manufacturer's instructions. Use of any other tools for stated operation is considered contrary to designated use. The risk of such use lies entirely with the user. The manufacturer cannot be held liable for damages as a result of misuse.

SAFE OPERATION

Read all safety information carefully. Safety instructions will be found throughout this manual and on the machine. Keep all safety information in good, readable condition. Operators should be well trained on the operation and maintenance of the trowel.

FAMILIARIZATION

The LD6 is a ride-on power trowel designed for the floating and finishing of concrete slabs.

Walk around the trowel and take note of the major components—engine, blades, air cleaner, fuel system, ignition switch, etc. Make sure there is always a proper level of lubricating oil in the engine and a proper level of hydraulic oil in the hydraulic oil reservoir.

Before using your trowel, test it on a flat, watered-down section of finished concrete. This test run will familiarize you with the trowel's controls and will increase your confidence in operating the trowel. You will learn how the trowel handles under actual operating conditions. Refer to the **Operation** section of this manual for more information.

ENGINE

The LD6 is equipped with a Vanguard 3864 gasoline engine. Refer to the engine owner's manual for specific instructions regarding engine operation and maintenance.

BLADES

The blades of the LD6 finish concrete as they are rotated across the surface. Blades are classified as *combination* (10 or 8 inches wide) or *finish* (6 inches wide). The LD6 is equipped with four blades per rotor equally spaced in a radial pattern and attached to a vertical rotating shaft by means of a spider assembly.

OPTIMIZED HYDRAULIC SYSTEM

The spider assemblies are driven by two high-torque hydraulic motors coupled to a variable displacement, axial piston hydraulic pump for increased overall system performance.

HYDRAULIC STEERING

Dual palm-grip joystick controls located to the left and right of the operator are provided for steering. The joysticks are linked to three hydraulic steering cylinders located within the frame of the machine.

OPTIONS

Optional kits for retardant spray and lights are available for the LD6 model only. Contact the Multiquip Parts Department for more information.

TRAINING

For proper training, please use the **Training Checklist** form located in the front of this manual. This checklist will provide an outline for an experienced operator to provide training to a new operator.

COMPONENTS (TROWEL)

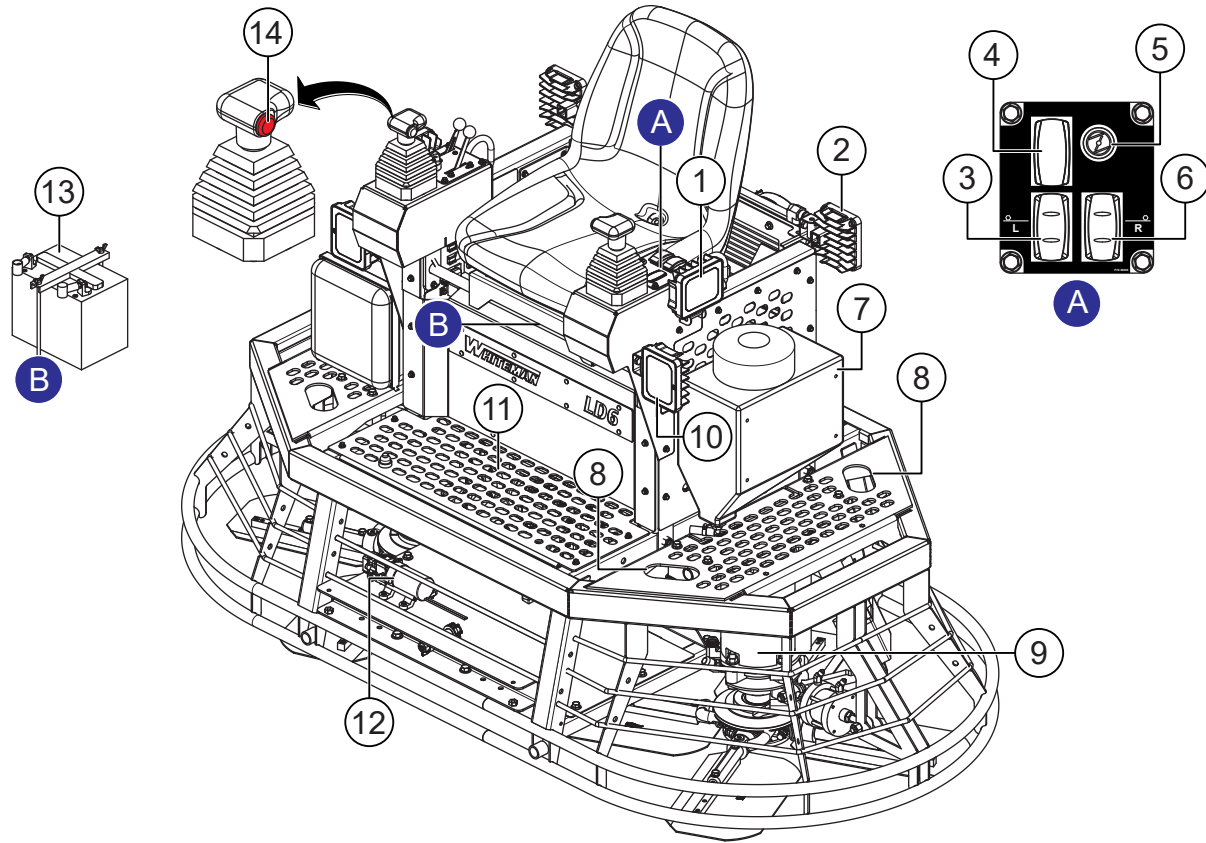

Figure 8. LD6 Trowel Components

1. **Light, Left Side (Optional)** — One of six LED lights included with the optional light kit.
2. **Light, Left Rear (Optional)** — One of six LED lights included with the optional light kit.
3. **Blade Pitch Control Switch (Left Side)** — Adjusts the left-side blade pitch independently of the right side.
4. **Light Switch** — Activates lights when the optional light kit is installed.
5. **Choke Knob** — The choke enriches the fuel mixture, and is used for starting a cold engine, or starting in cold weather conditions. In cold weather, pull this knob to start the engine. After the engine warms, push the knob all the way in.
6. **Blade Pitch Control Switch (Right Side)** — Adjusts the right-side blade pitch independently of the left side.
7. **Retardant Spray Tank (Optional)** — Part of the optional retardant spray kit. Remove the filler cap to add retardant to the tank. Holds up to 3 gallons (11.4 liters) of retardant.
8. **Tie-Down Locations (4)** — Secure tie-down straps to these attachment points when transporting the trowel.
9. **Hydraulic Motor (Left Side)** — This durable, high-torque hydraulic motor rotates the left-side spider assembly.
10. **Light, Left Front (Optional)** — One of six LED lights included with the optional light kit.
11. **Trowel Platform** — Use the trowel platform when boarding and deboarding the trowel.
12. **Retardant Spray Pump (Optional)** — Part of the optional retardant spray kit. Actuated by either of the buttons on the steering control handles, this pump controls the flow of retardant spray from the retardant tank to the spray nozzle.
13. **Battery** — Provides +12VDC to the electrical system. Tilt the operator's seat forward to access the battery.
14. **Retardant Spray Control Button (Right Side)** — Located on the right-side steering control handle, this button controls the flow of retardant spray when the optional retardant spray kit is installed.

COMPONENTS (TROWEL)

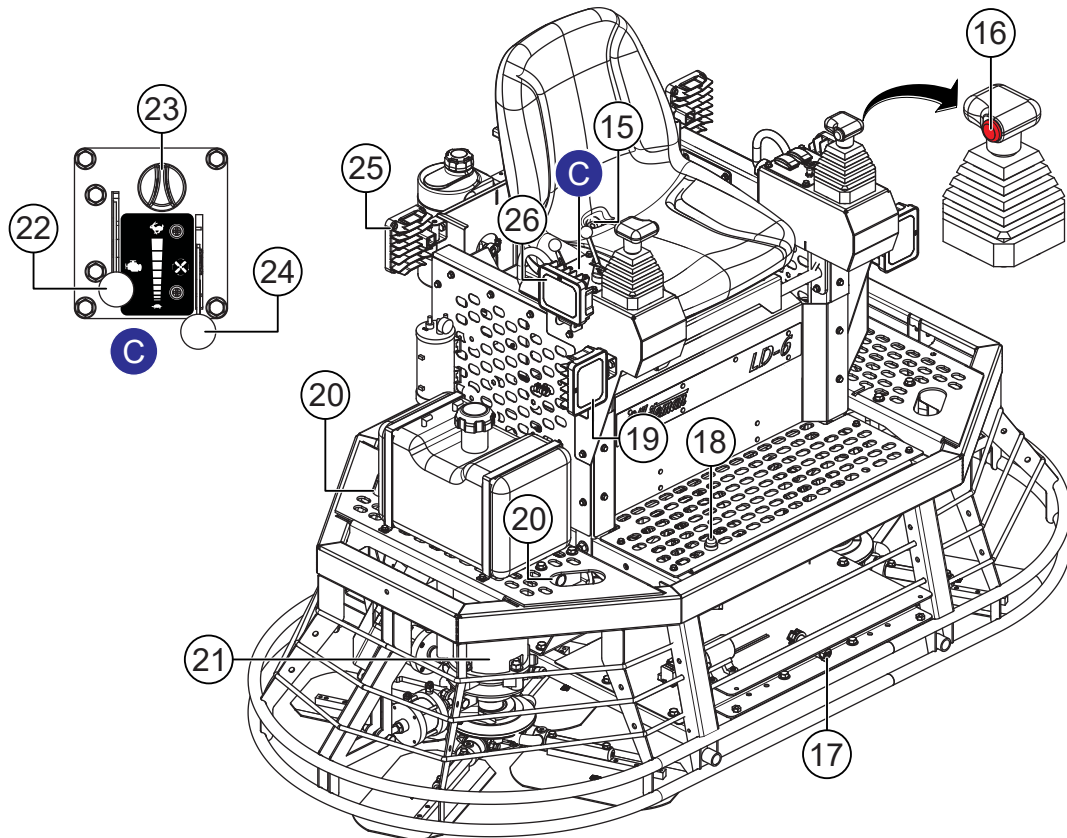

Figure 9. LD6 Trowel Components (Cont.)

- 15. **Seat Switch** — Safety feature stops blade rotation when the operator leaves the seat. The trowel blades will not rotate unless the operator is seated.
- 16. **Retardant Spray Control Button (Left Side)** — Located on the left-side steering control handle, this button controls the flow of retardant spray when the optional retardant spray kit is installed.
- 17. **Retardant Spray Nozzle (Optional)** — Part of the optional retardant spray kit. The spray nozzle delivers uniform coverage of retardant over the slab surface.
- 18. **Foot Switch** — Actuates the rotors. Depress the foot switch to turn the rotors. Release the foot switch to stop the rotors.
- 19. **Light, Right Front (Optional)** — One of six LED lights included with the optional light kit.
- 20. **Tie-Down Locations (4)** — Secure tie-down straps to these attachment points when transporting the trowel.
- 21. **Hydraulic Motor (Right Side)** — This durable, high-torque hydraulic motor rotates the right-side spider assembly.
- 22. **Engine Throttle Lever** — Controls engine speed. Push this lever forward to increase engine speed. Pull this lever backward to decrease engine speed.
- 23. **Key Switch** — Insert the ignition key here and turn clockwise to start the engine.
- 24. **Rotor Speed Control Lever** — Controls blade rotation speed. While holding down the foot switch, push the rotor speed control lever forward to increase rotor speed. Pull the lever backward to decrease rotor speed.
- 25. **Light, Right Rear (Optional)** — One of six LED lights included with the optional light kit.
- 26. **Light, Right Side (Optional)** — One of six LED lights included with the optional light kit.

COMPONENTS (TROWEL)

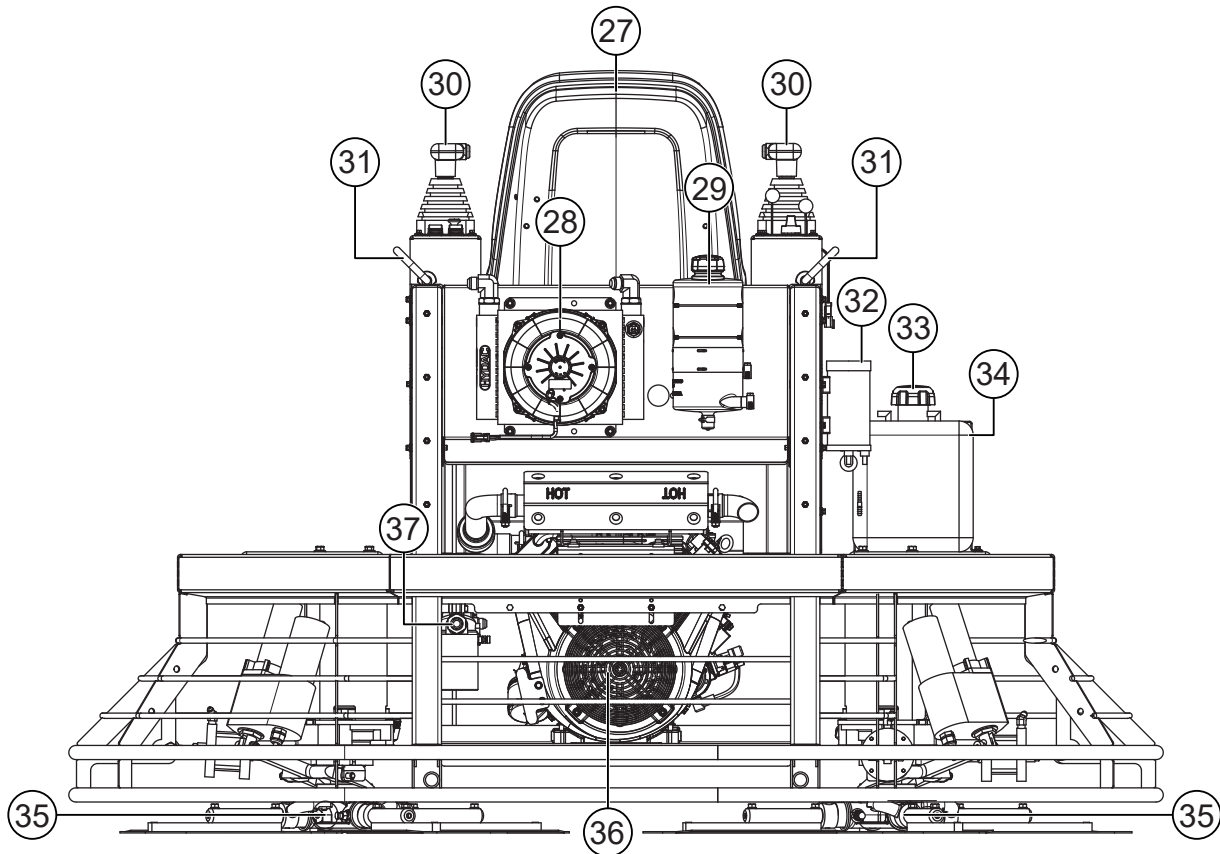

Figure 10. LD6 Trowel Components (Cont.)

- 27. **Operator's Seat** — Operator's seat tilts forward for service access.
- 28. **Heat Exchanger** — Keeps hydraulic oil at the optimum operating temperature.
- 29. **Hydraulic Oil Reservoir** — Visually inspect the level of hydraulic oil in the reservoir. Remove the filler cap to add hydraulic oil. Open **only** when the system is **cool**. Reservoir capacity is 2.2 gallons (10 liters). Use Parker DuraClean ISO 46 hydraulic oil only.
- 30. **Steering Control Handles (2)** — Located to the left and right of the operator, these dual palm-grip joysticks are linked to three hydraulic steering cylinders. Refer to the **Operation** section to learn more about steering.
- 31. **Lift Loops (2)** — Attach lifting slings here to lift the trowel. Refer to the **Lifting and Transporting** section for more information.
- 32. **Carbon Canister** — A container filled with activated charcoal traps gasoline vapor emitted by the fuel system and releases it to the engine. Reduces emissions and increases fuel efficiency.
- 33. **Fuel Filler Cap** — Remove the fuel filler cap to add unleaded gasoline to the fuel tank. Use 87 or 89 octane gasoline only.
- 34. **Fuel Tank** — Holds up to 4 gallons (15 liters) of unleaded gasoline. Use 87 or 89 octane gasoline only.
- 35. **Spider Assemblies (2)** — Each spider assembly has four trowel arms with 8-inch combination blades equally spaced in a radial pattern.
- 36. **Engine** — Vanguard 23-horsepower, small block, V-twin, horizontal shaft, air-cooled, OHV, gasoline engine. See the **Engine Components** section for more details.
- 37. **Hydraulic Filter** — Filters hydraulic fluid as it enters the system. Equipped with 10-micron, glass-filled filter media.

COMPONENTS (ENGINE)

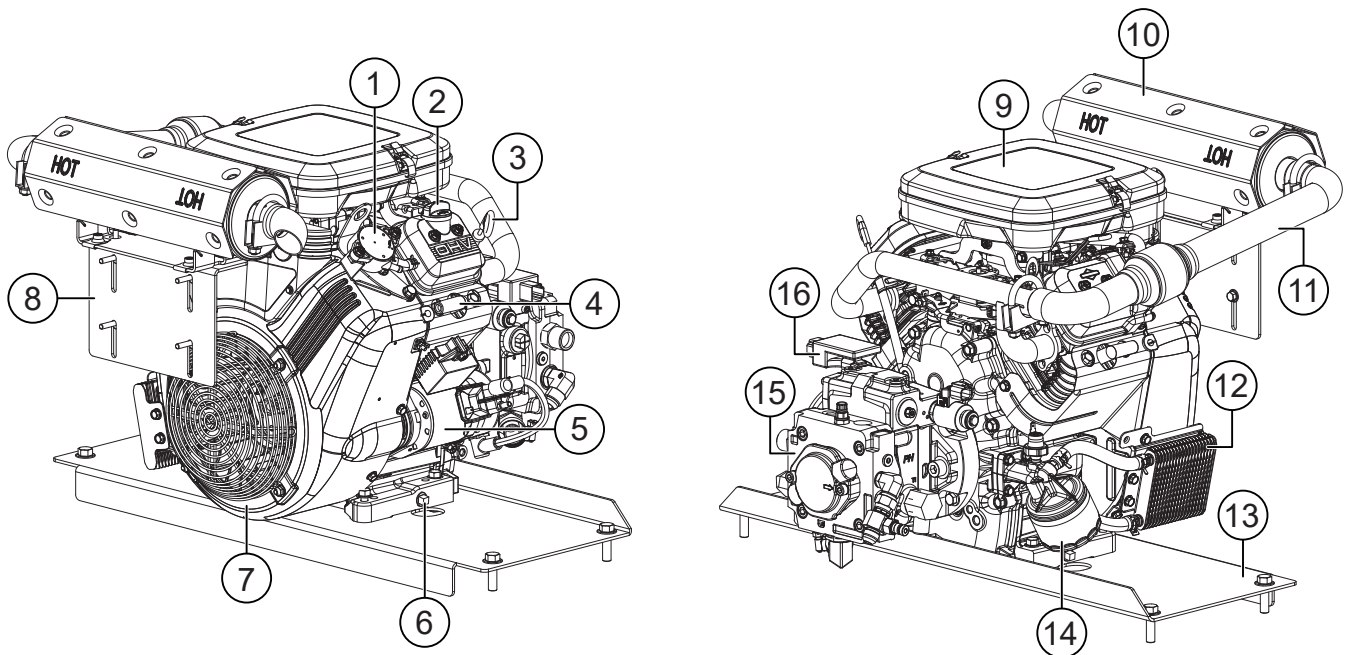

Figure 11. Vanguard Engine Components

1. **Fuel Pump** — Delivers gasoline fuel to the engine.
2. **Oil Fill Cap** — Remove the cap to add fresh engine oil. Refer to the *Inspection* or *Maintenance* section for more information.
3. **Oil Dipstick** — Remove to check the amount and condition of oil in the crankcase.
4. **Spark Plug** — Provides spark to the ignition system. Set the spark plug gap to 0.030 in. (0.76 mm).
5. **Starter** — Starts the engine when the ignition key is rotated to the **START** position.
6. **Oil Drain Plug** — Remove to drain engine oil.
7. **Blower Housing** — Contains the air cooling system.
8. **Muffler Mounting Bracket** — Secures the muffler to the trowel frame.
9. **Air Cleaner** — Prevents dirt and debris from entering the engine cylinders.
10. **Muffler** — Reduces noise and emissions. **NEVER** touch the muffler while the engine is running.
11. **Exhaust Pipe** — Transports harmful exhaust gases away from the engine interior.
12. **Oil Cooler** — Maintains engine oil temperature and viscosity.
13. **Engine Mounting Bracket** — Secures the engine to the trowel frame.
14. **Oil Filter** — Filters engine oil contaminants.
15. **Hydraulic Pump** — Variable displacement, axial piston pump drives the motors that turn the blades.
16. **Amplifier** — Receives input from the rotor speed control lever and sends proportional output current to the hydraulic pump valve.

BATTERY

⚠ CAUTION

Use all safety precautions specified by the battery manufacturer when handling the battery. See the **Safety Information** section of this manual for details on battery safety.

1. Tilt the operator's seat forward (Figure 12) to access the battery.

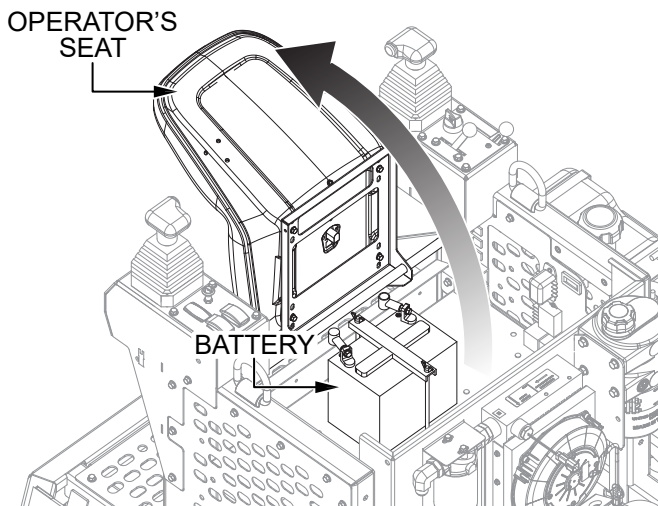

Figure 12. Battery Access

2. Make sure the battery is well secured in the battery tray with the two battery bolts (Figure 13).

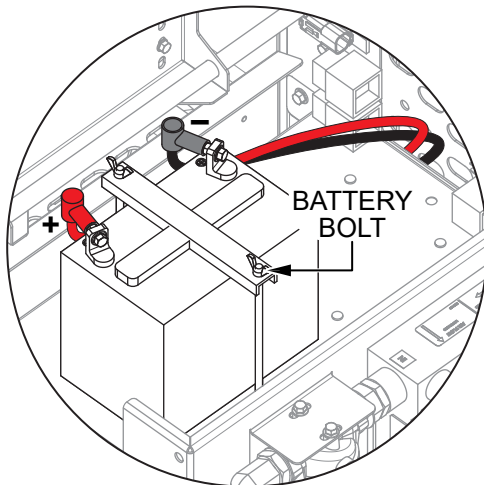

Figure 13. Battery Connection

3. Connect the positive (**RED**) battery cable to the positive (+) terminal on the battery, then connect the negative (**BLACK**) battery cable to the negative (-) terminal. See Figure 13.

FLOAT PAN INSTALLATION (OPTIONAL)

Float pans attach to the spider arms and allow early floating on wet concrete and easy movement from wet to dry areas. They are also very effective at embedding large aggregates and surface hardeners.

⚠ WARNING

ALWAYS install float pans either in the work area or in an area that is next to and level with the work area.

NEVER lift the trowel with float pans attached.

1. Make sure the blades are pitched completely flat (no pitch).
2. Lift the trowel just enough to slide a float pan under the blades. Lower the trowel onto the pan with the blades adjacent to the Z-clips (Figure 14).

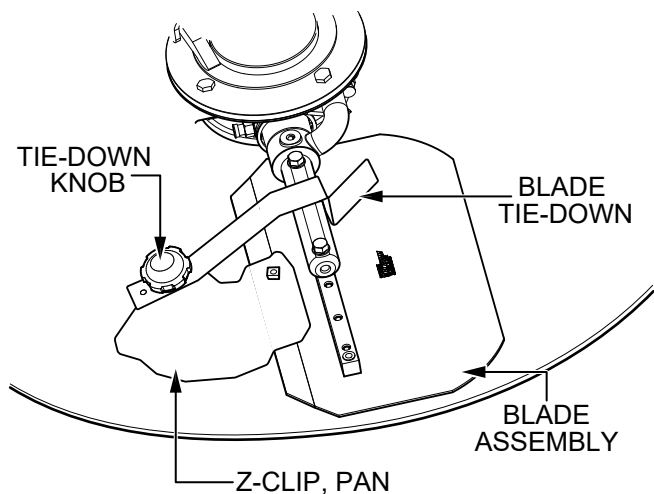

Figure 14. Float Pan Installation

3. Rotate the blades into position under the Z-clips. Make sure the blades are rotated in the same direction as when the machine is in operation, or use the engine to rotate the blades into position.
4. Attach the blade tie-downs to the far side of the Z-clip brackets with the tie-down knobs as shown in Figure 14.
5. Make sure the blade edges are secured under the Z-clips and the tie-downs are secured completely over the edges of the blade bar before the trowel is put back into operation.

ENGINE OIL

1. Make sure the trowel is on a secure, level surface with the engine stopped.
2. Pull the engine oil dipstick (Figure 15) out of its holder and wipe it with a clean cloth.

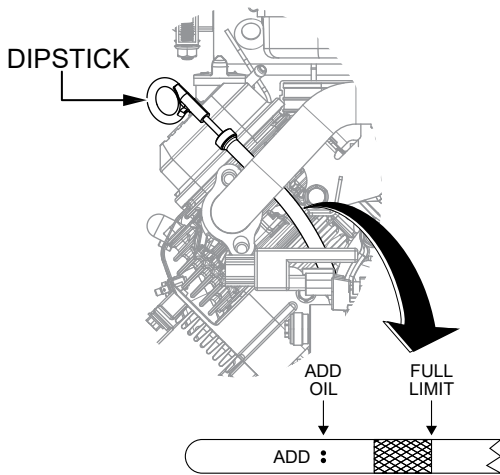

Figure 15. Engine Oil Dipstick

3. Fully insert the dipstick then remove it again.
4. Determine if engine oil is low. Oil should be between the upper and lower marks (Figure 15) on the dipstick.
5. If the oil is below the lower mark on the dipstick, remove the oil filler cap (Figure 16) and add engine oil up to the upper mark on the dipstick. Refer to Table 6 for recommended oil viscosity.

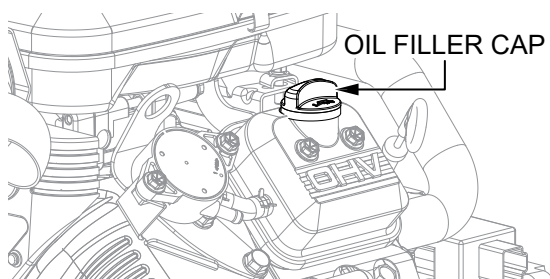
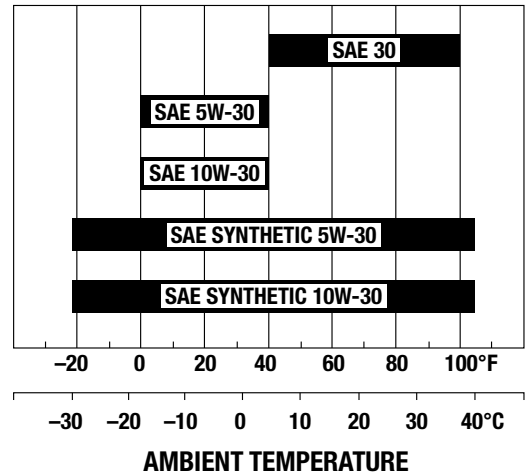

Figure 16. Oil Filler Cap

CAUTION

NEVER overfill the oil pan. **ALWAYS** allow time for any added oil to make its way to the oil pan before rechecking the level.

Table 6. Recommended Oil Viscosity Grades



6. When replacing the dipstick, make sure it is fully inserted into its holder to keep the crankcase sealed.

HYDRAULIC OIL

1. Make sure the trowel is on a secure, level surface with the engine stopped.
2. Visually inspect the level of hydraulic oil in the hydraulic oil reservoir (Figure 17). Hydraulic oil should be visible between the **MIN** and **MAX** lines on the reservoir.

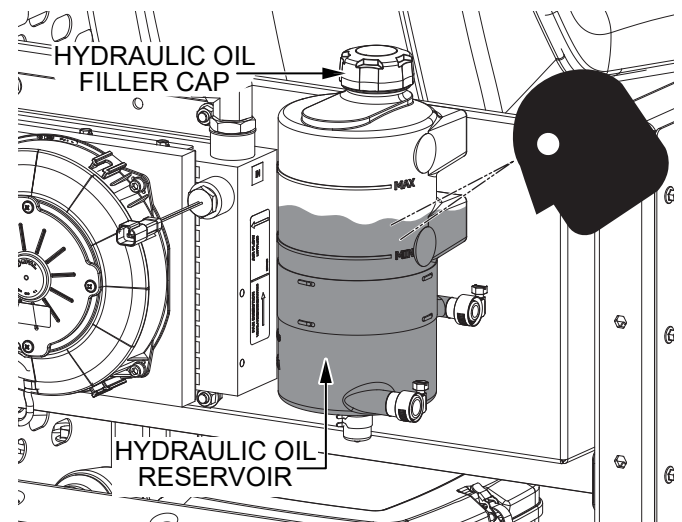

Figure 17. Hydraulic Oil Level Inspection

CAUTION



Hydraulic oil can get **HOT!**

ALWAYS allow hydraulic oil to cool before removing the fill cap. **NEVER** remove the fill cap when the oil is hot or spillage will occur.

DANGER



Fuel spillage on a **hot** engine can cause a **fire** or **explosion**. If fuel spillage occurs, wipe up the spilled fuel completely to prevent fire hazards. **NEVER** smoke around or near the trowel.

3. If the hydraulic oil level is low, remove the hydraulic oil filler cap (Figure 17) and add hydraulic oil up to a level midway between the **MIN** and **MAX** lines on the reservoir. **DO NOT** overfill. Use only Parker DuraClean ISO 46 hydraulic oil. Replace the cap when finished.

4. Replace the fuel filler cap when finished adding fuel.

FUEL

DANGER

Gasoline fuel is **highly flammable** and can be dangerous if mishandled.

NEVER smoke while refueling. **NEVER** attempt to refuel while the engine is hot or running.

1. Make sure the trowel is on a secure, level surface with the engine stopped.
2. Visually inspect the fuel level in the tank (Figure 18).

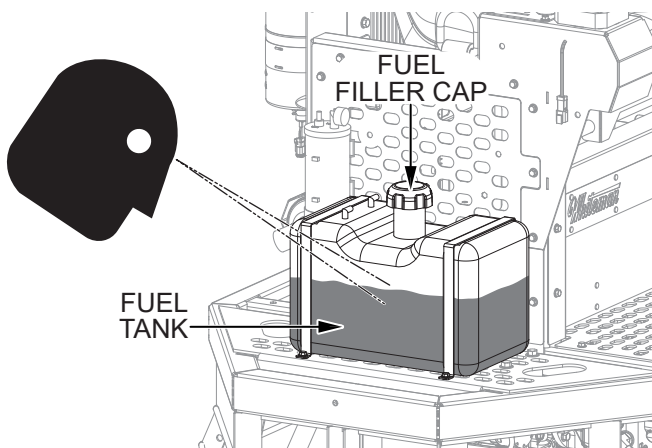

Figure 18. Fuel Level Inspection

3. If fuel is low, remove the fuel filler cap (Figure 18) and fill the tank with unleaded 87 or 89 octane gasoline. **DO NOT** overfill. The fuel tank holds 4 gallons (15 liters) of gasoline.

OPERATION

The following section is intended to assist the operator with operation of the trowel. It is extremely important to read this section carefully before attempting to use the trowel in the field. **DO NOT** operate the trowel until this section is thoroughly understood.

CAUTION



ALWAYS wear approved eye and hearing protection while operating the trowel.

WARNING



NEVER operate the trowel in a confined area or enclosed structure that does not provide an ample, free flow of air.

NOTICE

This trowel is equipped with a safety seat switch. The trowel blades will not rotate unless an operator is sitting in the seat.

STARTING THE ENGINE

1. Place one foot on the trowel's platform and grab part of the frame, then lift yourself onto the trowel and sit down in the operator's seat.

NOTICE

DO NOT grab the steering control joysticks to lift yourself onto the trowel. Damage to the joysticks may result.

2. If starting a cold engine, or starting the engine in cold weather, pull the choke knob (Figure 19) **outward** to the **CLOSED** position.

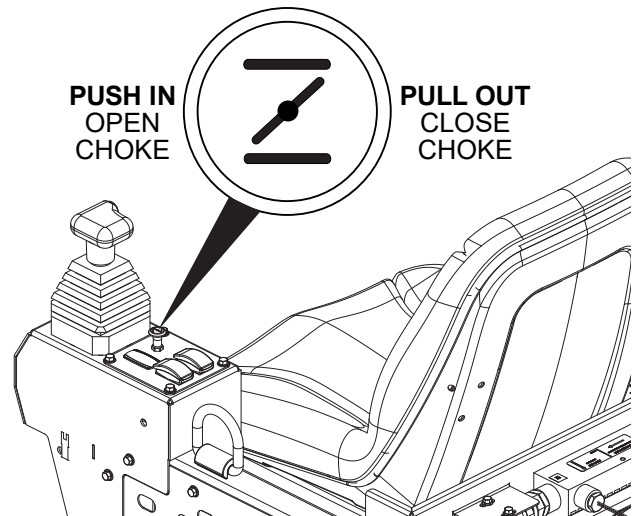

Figure 19. Choke Knob

3. Place the engine throttle lever in the **IDLE** (turtle) position. See Figure 20.

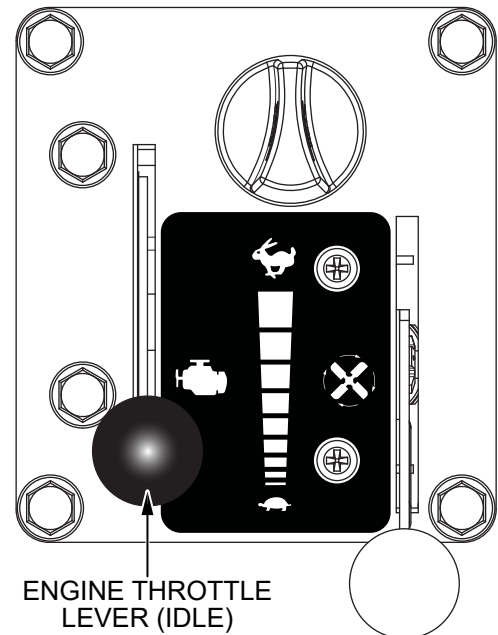

Figure 20. Engine Throttle Lever (Idle)

OPERATION

- Insert the ignition key into the ignition switch (Figure 21). While keeping your foot **off** the foot switch, turn the ignition key **clockwise** to the **START** position. Once the engine starts, release the ignition key.

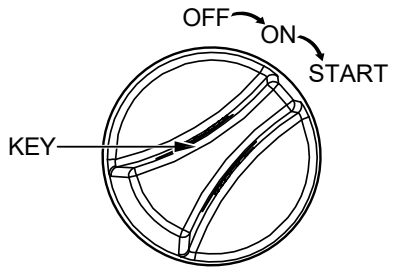

Figure 21. Ignition Key Switch (Start)

NOTICE

If the engine fails to start, consult the engine owner's manual supplied with the trowel.

- Let the engine idle for 2–3 minutes. Once the engine has warmed, push the choke knob (Figure 19) **inward** to the **OPEN** position.

NOTICE

DO NOT allow the engine to run unattended at a high idle position for longer than 5 minutes. The hydraulic system will overheat if the engine idles for too long without spinning the rotors.

- Place the engine throttle lever in the **FAST** (rabbit) position. See Figure 22.

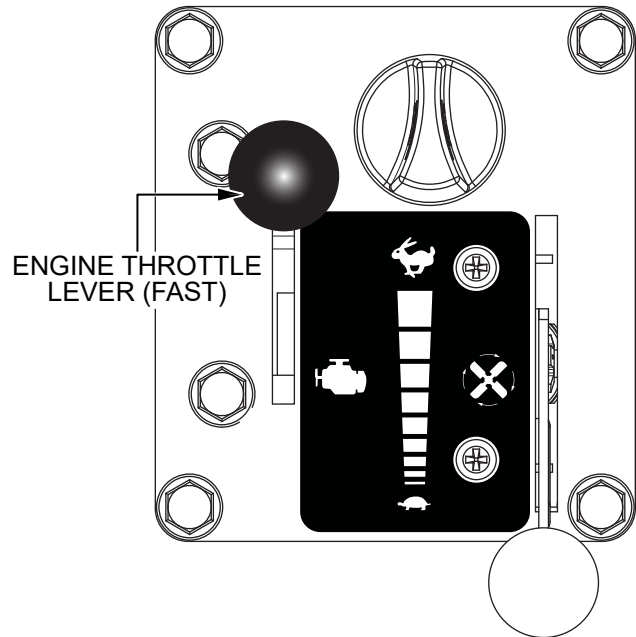

Figure 22. Engine Throttle Lever (Fast)

TESTING THE SEAT SWITCH

Make sure the safety seat switch is operational prior to using the trowel each day.

- With the engine running, depress the foot switch to start turning the rotors. Observe that the blades are rotating.
- While keeping the foot switch depressed, rise from the operator's seat.
- Verify that the blades stop rotating while the engine continues to run.
- If blade rotation has stopped, the seat switch is working.
- If blade rotation continues, the seat switch is not working. Stop the engine immediately and correct the problem.

WARNING

NEVER disable or disconnect the seat switch. It is provided for operator safety. Injury may result if it is disabled, disconnected or improperly maintained.

STEERING

Two palm-grip joysticks (Figure 23) located to the left and right of the operator's seat provide directional control of the trowel.

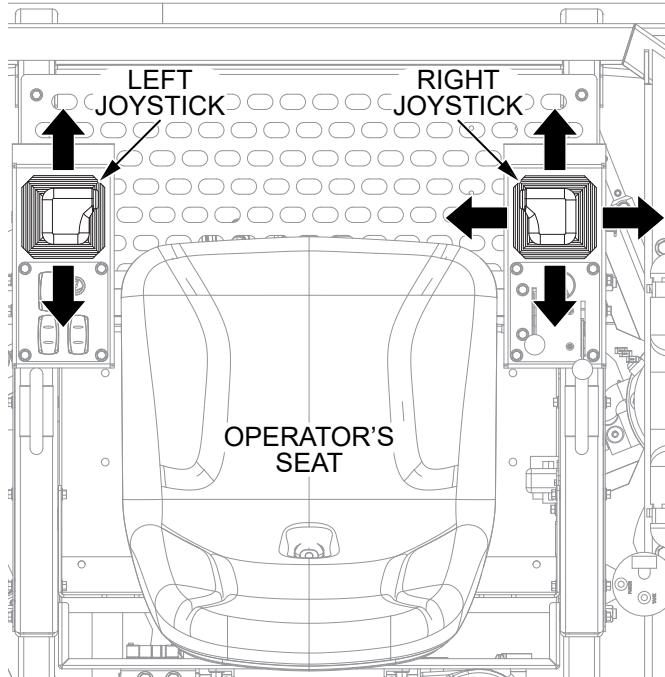





Figure 23. Steering Control Joysticks

Table 7 illustrates the various directional positions of the joysticks and their effect on the movement of the trowel.

NOTICE

All directional references with respect to the joysticks are from the operator's seated position.

Table 7. Joystick Directional Positioning

CONTROL JOYSTICK & DIRECTION	RESULT
Move LEFT Joystick FORWARD ↑	 Causes only the left side of the ride-on trowel to move forward.
Move LEFT Joystick BACKWARD ↓	 Causes only the left side of the ride-on trowel to move backward.
Move RIGHT Joystick FORWARD ↑	 Causes only the right side of the ride-on trowel to move forward.
Move RIGHT Joystick BACKWARD ↓	 Causes only the right side of the ride-on trowel to move backward.
Move BOTH Joysticks FORWARD ↑ ↑	Causes the ride-on trowel to move forward in a straight line. ↑ ↑
Move BOTH Joysticks BACKWARD ↓ ↓	Causes the ride-on trowel to move backward in a straight line. ↓ ↓
Move RIGHT Joystick to the RIGHT ⇒⇒⇒	Causes the ride-on trowel to move to the right. ⇒⇒⇒
Move RIGHT Joystick to the LEFT ⇐⇐⇐	Causes the ride-on trowel to move to the left. ⇐⇐⇐

OPERATION

The rotor speed control lever (Figure 24) controls rotor speed in conjunction with the foot switch (Figure 25). The foot switch rotates the blades while the position of the rotor speed control lever determines the rotational speed of the blades.

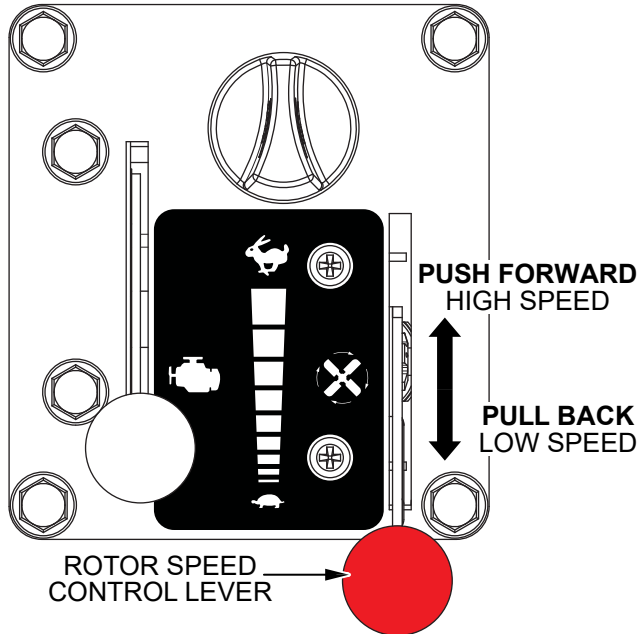

Figure 24. Rotor Speed Control Lever

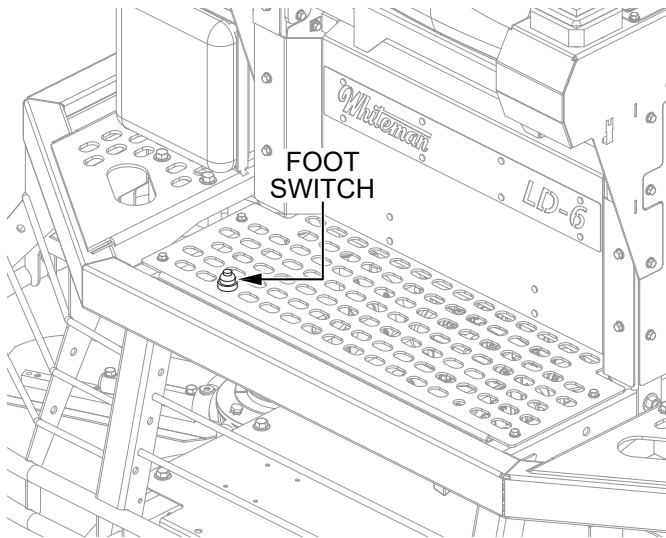

Figure 25. Foot Switch

1. With the engine running, depress and hold the foot switch (Figure 25) with your right foot to begin rotating the blades.
2. Move the rotor speed control lever to about midway between high speed (rabbit) and low speed (turtle).

3. Push both the left and right joysticks **forward** (Figure 26). Notice that the trowel begins to move in a forward direction. Release both joystick controls to stop forward movement, then remove your right foot from the foot switch to stop blade rotation.

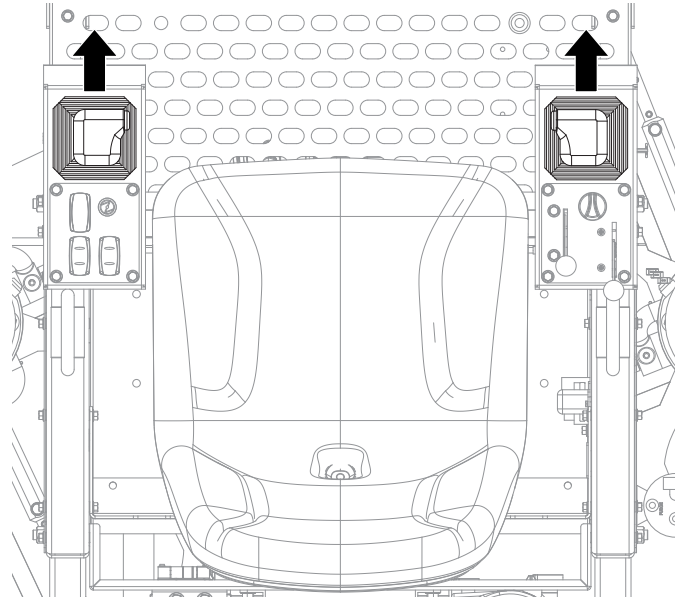

Figure 26. Joysticks (Forward)

4. Practice holding the machine in one place as you increase blade speed. When about 75% of maximum blade speed has been reached, the blades will be moving at proper finishing speed. The machine may be difficult to keep in one place. Trying to keep the trowel stationary is good practice for operation.
5. Practice maneuvering the trowel using the information in Table 7. Practice controlled motions as if finishing a slab of concrete. Practice edging and covering a large area.

6. Try adjusting the pitch of the blades using the left and right blade pitch control switches (Figure 27). This can be done with the trowel stopped or while the trowel is moving.

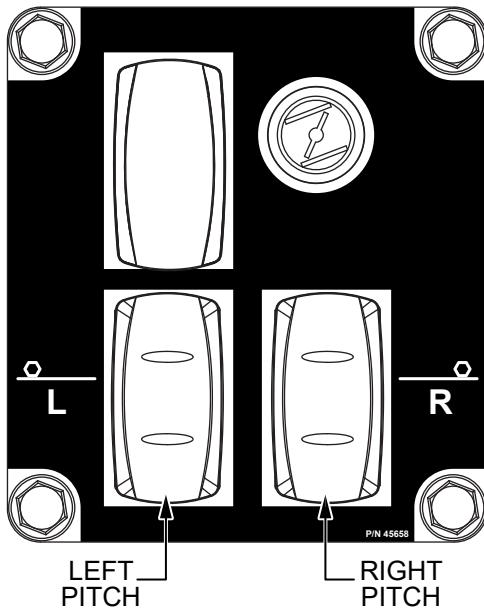

Figure 27. Blade Pitch Control Switches

7. Test the operation of optional equipment such as retardant spray and lights.
8. Pull both the left and right joysticks **backward** (Figure 28) and repeat steps 3–4 while substituting the word *reverse* for *forward*.

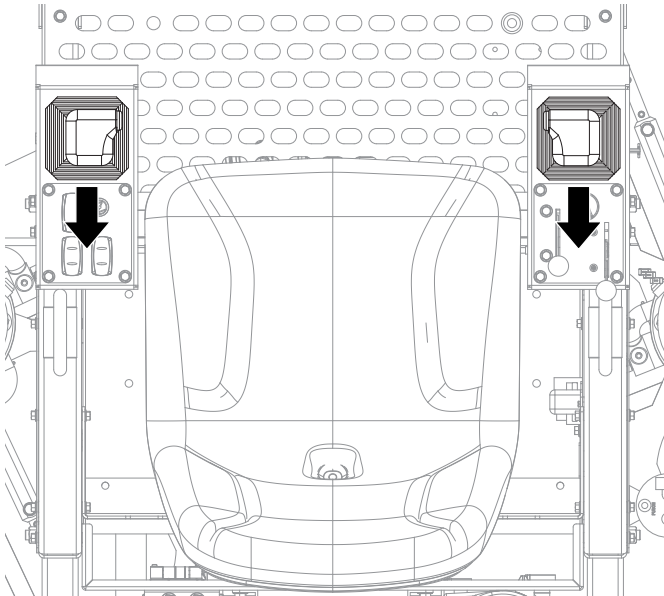

Figure 28. Joysticks (Reverse)

ENGINE SHUTDOWN

1. Reduce engine speed and allow the engine to idle for 3–5 minutes.

NOTICE

Failure to allow the engine to idle for a few minutes before shutdown may lead to engine damage.

NOTICE

DO NOT allow the engine to run unattended at a high idle position for longer than 5 minutes. The hydraulic system will overheat if the engine idles for too long without spinning the rotors.

2. Turn the ignition key counterclockwise to the **OFF** position, then remove the key.
3. Clean and remove any debris from the trowel.

MAINTENANCE

Table 8. Maintenance Schedule

Check Item	Periodic Maintenance Interval			
	Daily	Every 25 hours	Every 100 hours	Every 400 hours
Visual check for fluid leaks	X			
Check engine oil level	X			
Grease trowel arms	X			
Change engine oil and filter ¹			X	
Service air cleaner pre-cleaner ²		X		
Service air cleaner cartridge ²			X	
Change hydraulic oil filter ³	After the first 100 hours of operation, then after every 250 hours of operation			
Inspect electrical wiring for cuts, abrasions or corrosion	After the first 50 hours of operation, then after every 100 hours of operation			
Check all fasteners for tightness				X
Clean cooling system			X	
Clean/replace spark plugs	Every 100–400 hours			
Clean/replace fuel filter				
Check valve clearance				
<p>Note 1 = Change oil after the first 5 to 8 hours of use, then every 100 hours. Change oil every 50 hours when operating the engine under heavy load or in high temperatures.</p> <p>Note 2 = Clean more often under dusty conditions or when airborne debris is present. Replace the air cleaner if very dirty.</p> <p>Note 3 = Use Parker DuraClean ISO 46 hydraulic oil only.</p>				

CAUTION

Certain maintenance operations or machine adjustments require specialized knowledge and skill. Attempting to perform maintenance or adjustments without the proper knowledge, skills or training could result in equipment damage or injury to personnel. When in doubt, consult your dealer.

CLEANUP

NEVER allow concrete to harden on the trowel. Wash any concrete off the trowel with water immediately after use. Be careful to not spray a hot engine or muffler. An old paint brush or broom may help loosen any concrete that has started to harden.

COOLING SYSTEM

Debris may clog the engine's air cooling system. Remove the blower housing and clean the areas shown in Figure 29 to prevent overheating and engine damage.

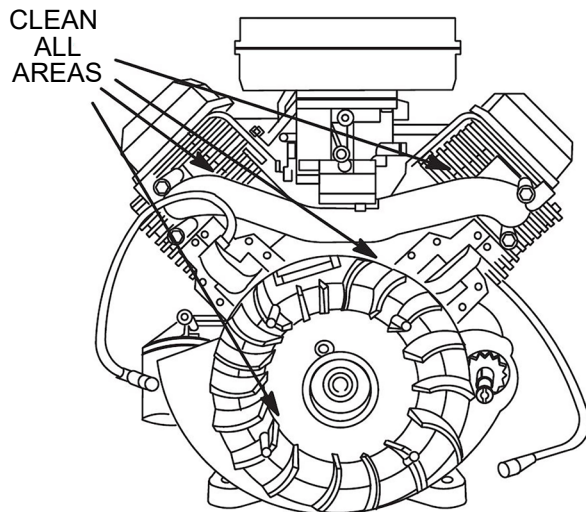

Figure 29. Cleaning the Air Cooling System

AIR CLEANER

The engine air cleaner assembly is equipped with a round air cleaner cartridge and a foam pre-cleaner. Clean or replace the air cleaner elements as necessary.

NOTICE

Operating the engine with loose or damaged air cleaner components could allow unfiltered air into the engine, causing premature wear and failure.

NOTICE

NEVER run the engine with the air cleaner removed.

1. Release the latches (Figure 30) on each side of the air cleaner cover and remove the cover.

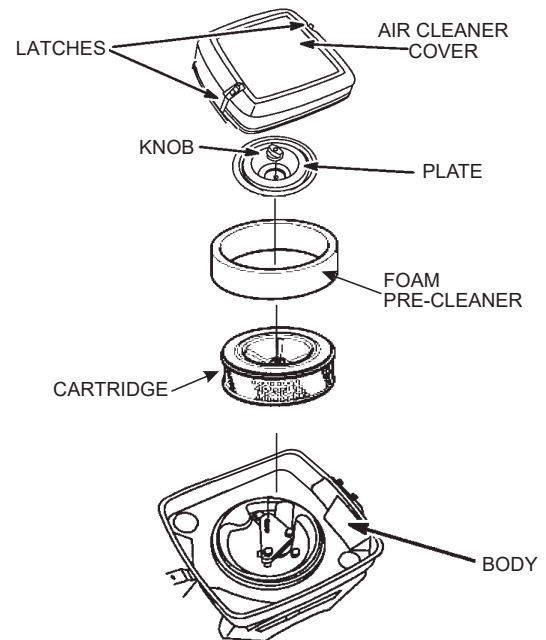

Figure 30. Air Filter Components

2. Remove the knob and the plate (Figure 30).
3. Remove the foam pre-cleaner and cartridge (Figure 30) carefully to prevent dirt and debris from entering the carburetor.

4. Inspect the pre-cleaner and cartridge. Replace the cartridge if it is excessively dirty.

NOTICE

DO NOT use solvents or pressurized air to clean the cartridge. Pressurized air can damage the cartridge, and solvents will dissolve the cartridge.

5. Wash the foam pre-cleaner (Figure 31) in liquid detergent and water and squeeze dry in a clean cloth.

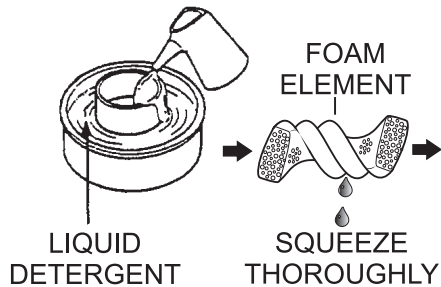

Figure 31. Cleaning the Foam Pre-Cleaner

6. Assemble the clean (or new) foam pre-cleaner onto a new cartridge.
7. Reinstall the new air cleaner assembly with the plate and knob into the body.
8. Replace the air cleaner cover and secure with the latches.

ENGINE OIL

1. Make sure the trowel is on a secure, level surface with the engine stopped.

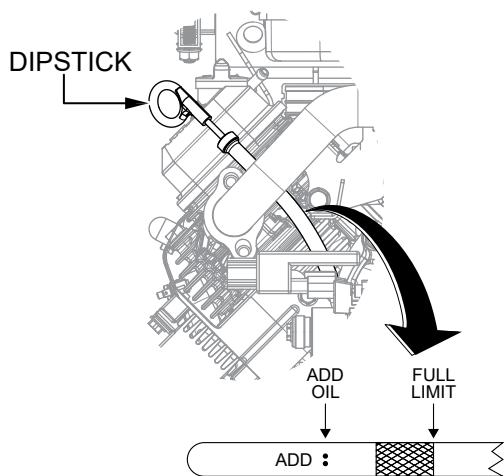

Figure 32. Engine Oil Dipstick

2. Pull the engine oil dipstick (Figure 32) out of its holder and wipe it with a clean rag.
3. Fully insert the dipstick then remove it again.
4. Determine if engine oil is low. Oil should be between the upper and lower marks (Figure 32) on the dipstick.
5. If the oil is below the lower mark on the dipstick, remove the oil filler cap (Figure 33) and add engine oil up to the upper mark on the dipstick. Refer to Table 6 for recommended oil viscosity.

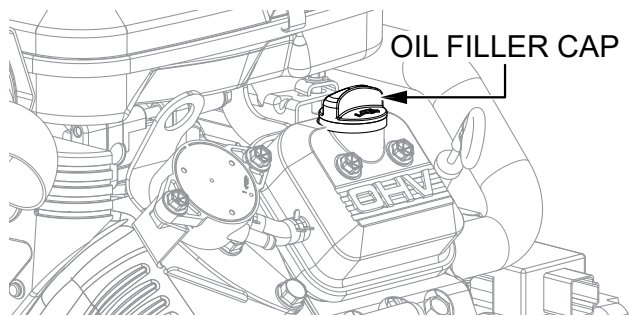

Figure 33. Oil Filler Cap

CAUTION

NEVER overfill the oil pan. **ALWAYS** allow time for any added oil to make its way to the oil pan before rechecking the level.

6. When replacing the dipstick, make sure it is fully inserted into its holder to keep the crankcase sealed.

Changing Engine Oil and Filter

Change the engine oil after the first 5 to 8 hours of operation, then every 100 hours. Change the oil every 50 hours when operating under heavy load or in high temperatures. Refer to Table 6 for recommended oil viscosity.

NOTICE

ALWAYS drain the engine oil while the oil is **warm**.

1. Make sure the engine is level.
2. Disconnect the spark plug wire and keep it away from the spark plugs.
3. Disconnect the negative (black) battery cable from the negative battery terminal.

MAINTENANCE

- Remove the oil drain plug (Figure 34) and allow the oil to drain into a suitable container through the drain hole in the engine mounting bracket.

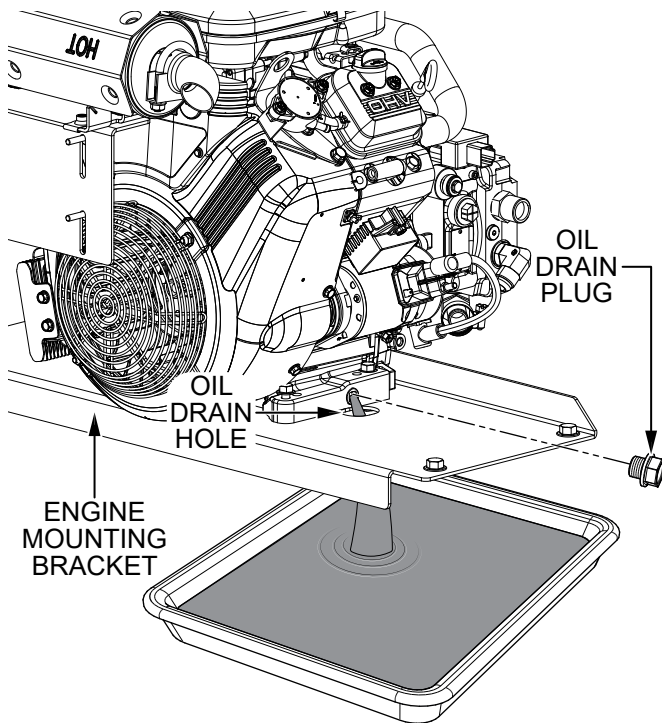

Figure 34. Engine Oil Replacement

- After the oil has fully drained, reinstall the oil drain plug.
- Using a filter wrench (Figure 35), turn the oil filter counterclockwise to remove.

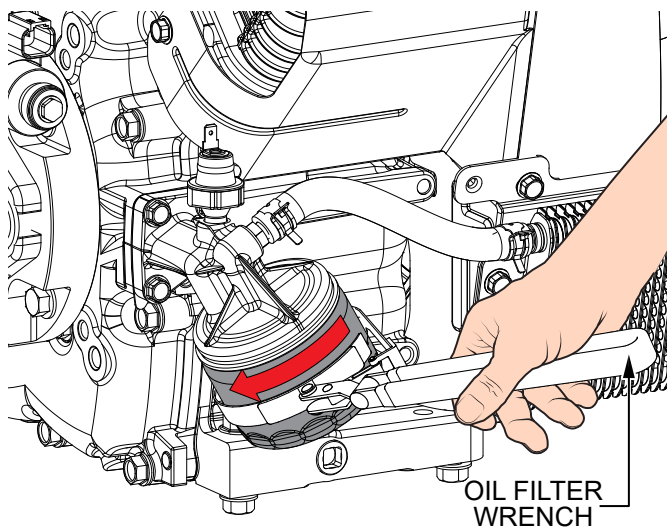

Figure 35. Oil Filter Removal

- Clean the sealing surface where the filter mounts onto the engine.

- Coat the seal of the new oil filter (Figure 36) with clean engine oil. Install the new filter by hand until it contacts the engine sealing surface, then tighten it another 1/2 to 3/4 turn. **DO NOT** use a strap wrench or similar tool to tighten the filter.

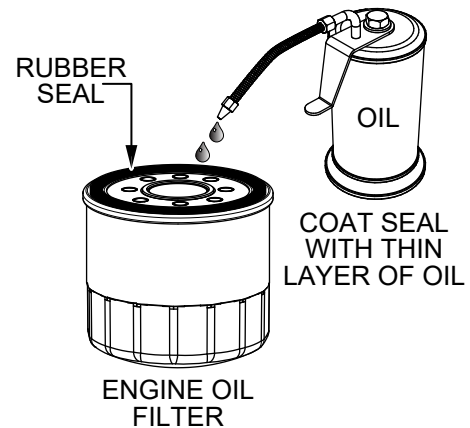

Figure 36. Oil Filter

- Remove the oil filler cap and add 1 quart (32 oz./1 liter) of oil to the engine.
- Start and run the engine at idle for 30 seconds.
- Shut down the engine and wait 30 seconds. Then slowly add more oil to bring the level up to the **FULL** mark on the dipstick. Refer to Table 3 for engine oil capacity. **DO NOT** overfill.
- Replace the oil filler cap and make sure the dipstick is fully inserted.

SPARK PLUGS

- Make sure the engine is cool before servicing the spark plugs.
- Loosen the spark plugs and remove any dirt from around the spark plug area.
- Remove and inspect the spark plugs. Replace the spark plugs if they are damaged, the sealing washer is in poor condition, or the electrode is burned or worn.

4. Measure the spark plug electrode gap (Figure 37) with a wire-type feeler gauge. If needed, adjust the gap to 0.030 in. (0.76 mm) by carefully bending the side electrode.

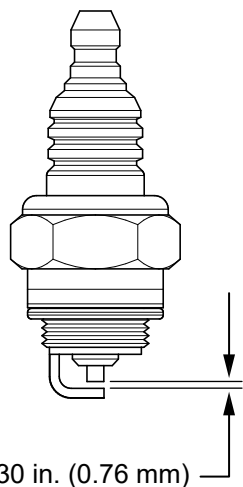

GAP: 0.030 in. (0.76 mm)

Figure 37. Spark Plug Gap

5. Install the spark plug carefully, by hand, to avoid cross-threading.
6. After the spark plug is seated, tighten with a spark plug wrench to 15 lbf-ft (20.3 N-m).

FUEL FILTER

Clean or replace the engine fuel filter (Figure 38) every 100–400 hours of operation.

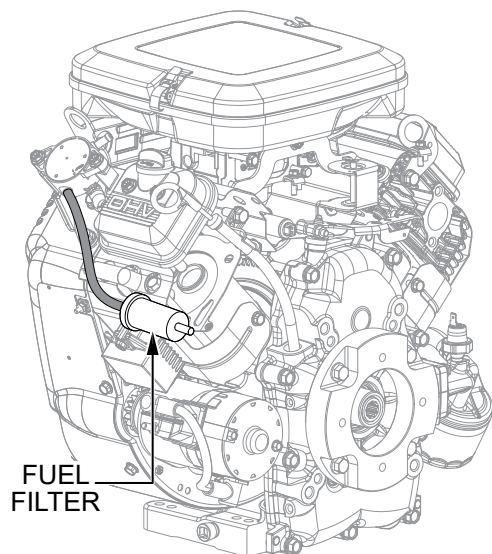

Figure 38. Engine Fuel Filter

HYDRAULIC OIL FILTER

Change the hydraulic oil filter (Figure 39) after the first 100 hours of use, then every 250 hours. Use 10-micron, glass-filled filter elements only.

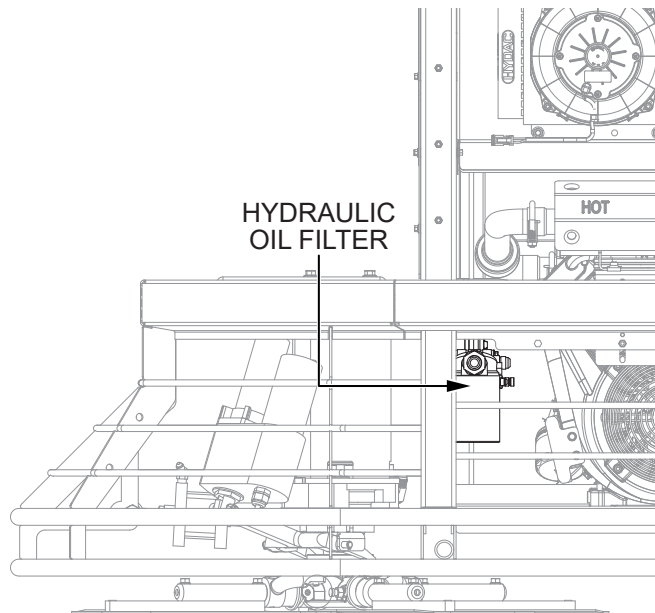

Figure 39. Hydraulic Oil Filter

Draining the Hydraulic Oil

CAUTION



Hydraulic oil can get **HOT!**

ALWAYS allow hydraulic oil to cool before performing this procedure.

1. Place an appropriate container beneath the hydraulic oil reservoir (Figure 40) to catch the hydraulic oil as it drains.

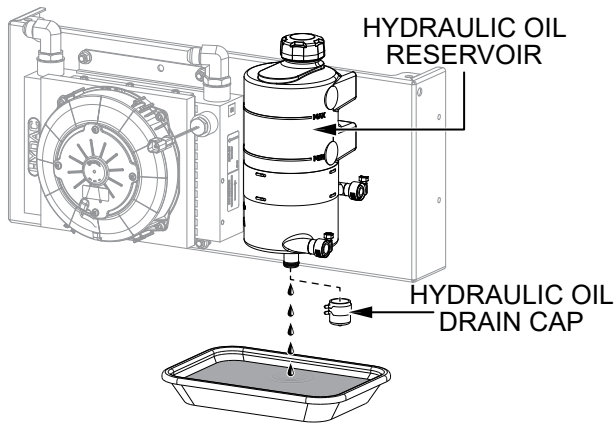

Figure 40. Draining Hydraulic Oil

2. Remove the hydraulic oil drain cap (Figure 40) and allow the hydraulic oil to drain completely from the reservoir.
3. Replace the drain cap when finished.

BATTERY

1. Check and clean the battery terminals for corrosion.
2. Disconnect the negative (-) battery terminal during storage. If the unit will be stored where the ambient temperature will drop to -15°C or less, remove and store the battery in a warm, dry place.
3. Check the manufacturer's recommendations for maintaining and charging the battery.

NOTICE

NEVER attempt to charge a battery that is frozen. **The battery can explode** unless first allowed to thaw.

TROWEL LUBRICATION

Regular lubrication is required to maintain your trowel in optimal working condition. Perform the following lubrication procedure after **every 8 hours of operation**.

1. Locate one of the Zerk grease fittings on either spider assembly (Figure 41). Remove the Zerk fitting cap and set it aside.

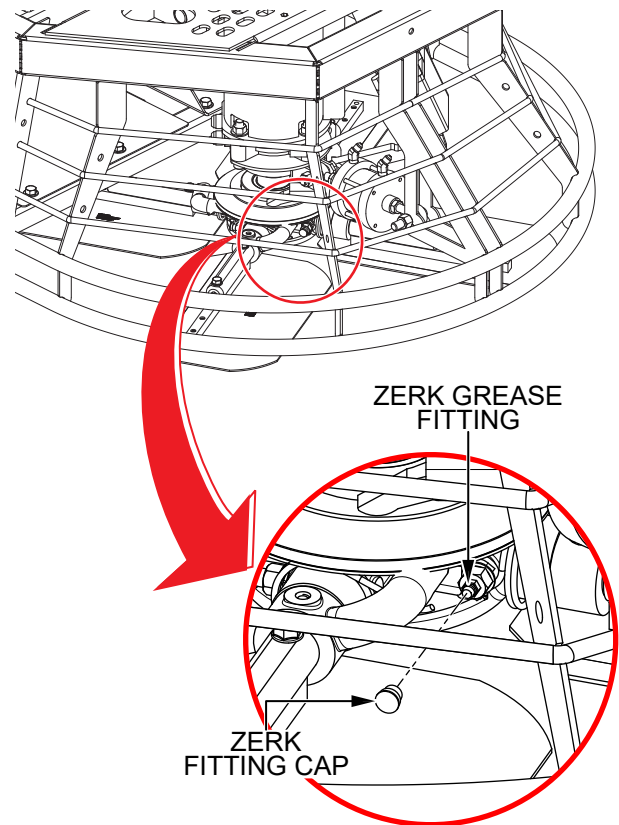

Figure 41. Spider Lubrication

2. Wipe the Zerk grease fitting clean to prevent abrasive material from entering the fitting during lubrication.
3. Lubricate the Zerk grease fitting with 1–1½ shots of multipurpose grade grease. Replace the Zerk grease fitting cap when finished.
4. Repeat steps 1–3 for the remaining grease fittings on both spider assemblies.

BLADE PITCH ADJUSTMENT

Perform maintenance adjustment of blade pitch using a bolt on the trowel arm lever (Figure 42). This bolt is the contact point of the trowel arm with the lower wear plate on the thrust collar. The goal of adjustment is consistent blade pitch and finishing quality.

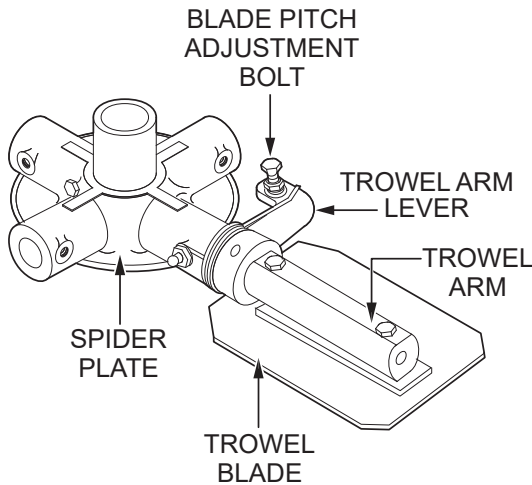

Figure 42. Blade Pitch Adjustment Bolt

Look for the following indications when determining if blade pitch adjustment is necessary:

- Are the blades wearing out unevenly (e.g. one blade is completely worn out while the others look new)?
- Does the machine have a perceptible rolling or bouncing motion while in use?
- Does the guard ring rock up and down while the machine is in use?

Once it has been determined that blade pitch adjustment is necessary, do the following:

1. Place the trowel on a flat, level surface, with blocks under the main guard ring for support. Any uneven spots in the floor or debris under the trowel blades will cause an incorrect perception of adjustment. Ideally, a 5 ft. x 5 ft. (1.5 m x 1.5 m), 3/4 inch-thick, **flat** steel plate should be used.

2. Pitch the blades as flat as possible. The adjustment bolts should all barely make contact with the lower wear plate on the spider. Figure 43 illustrates the correct alignment for a spider plate as shipped from the factory.

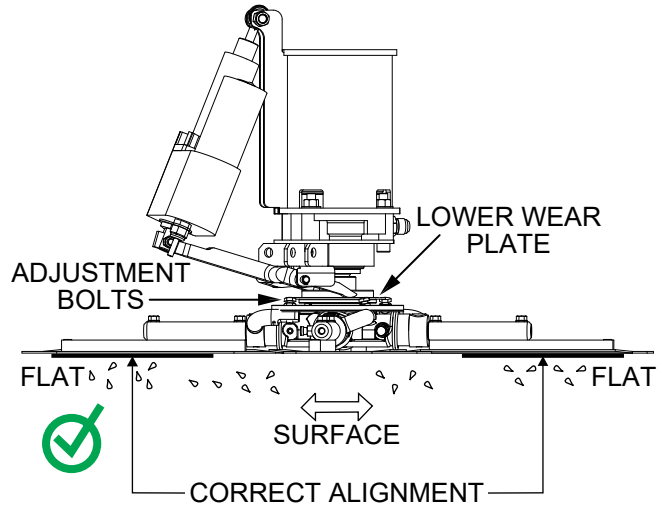

Figure 43. Correct Spider Plate Alignment

3. If any adjustment bolts are not making contact with the lower wear plate, adjustment will be necessary. Figure 44 illustrates incorrect alignment, worn spider bushings, or bent trowel arms.

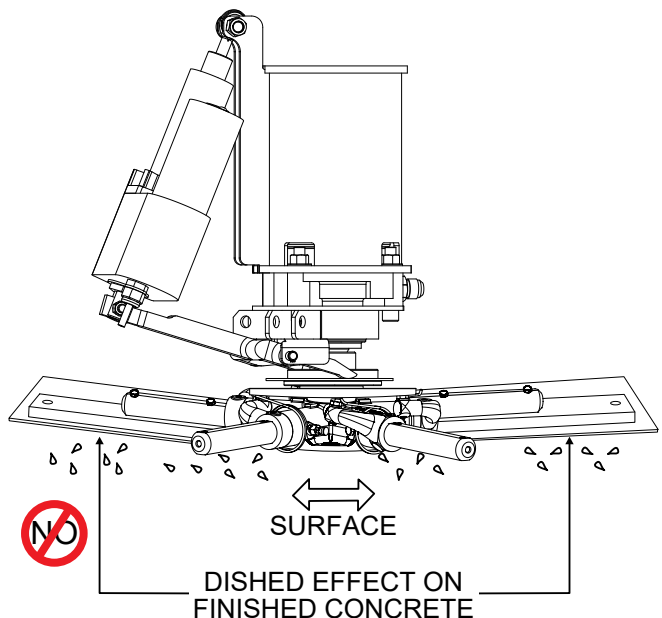

Figure 44. Incorrect Spider Plate Alignment

SPIDER REMOVAL

1. Remove and set aside the cap plug and retaining screw securing the spider assembly to the hydraulic motor shaft (Figure 45).

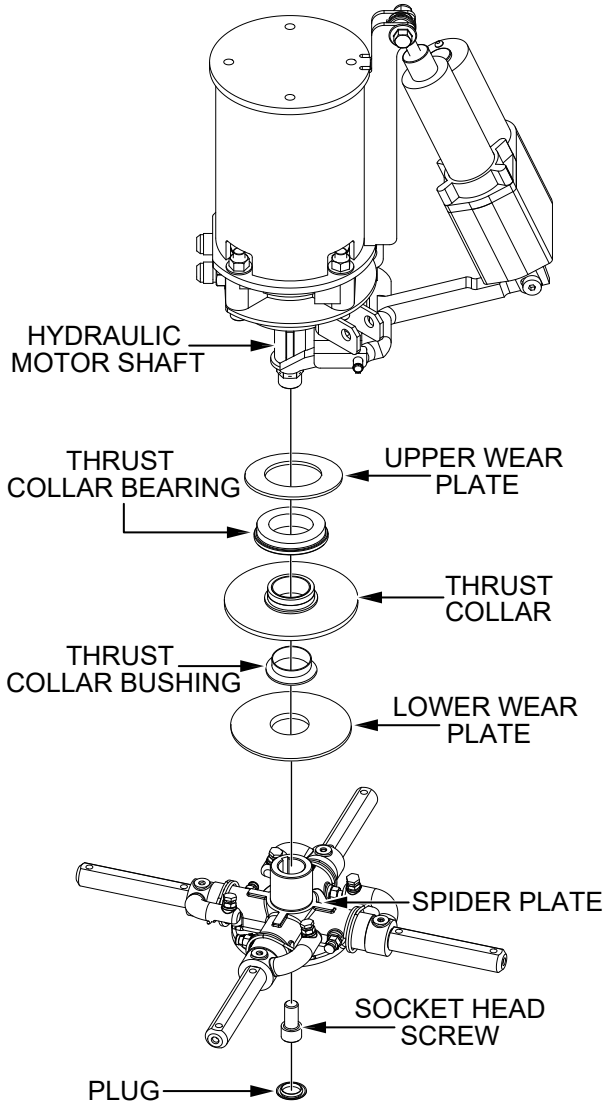

Figure 45. Spider Removal

2. Carefully lift the upper trowel assembly off of the spider assembly. A slight tap with a rubber mallet may be necessary to dislodge the spider from the hydraulic motor shaft.

BLADE REPLACEMENT

It is recommended to replace **all** of the trowel blades at the same time. If only one or some of the blades are changed, the machine may wobble or bounce and will not finish concrete consistently.

NOTICE

Please note the orientation of each blade on the trowel arm before removal.

1. Place the trowel on a flat, level surface, with blocks under the main guard ring for support.
2. Remove the bolts from each of the trowel arms, then remove the blades as shown in Figure 46.

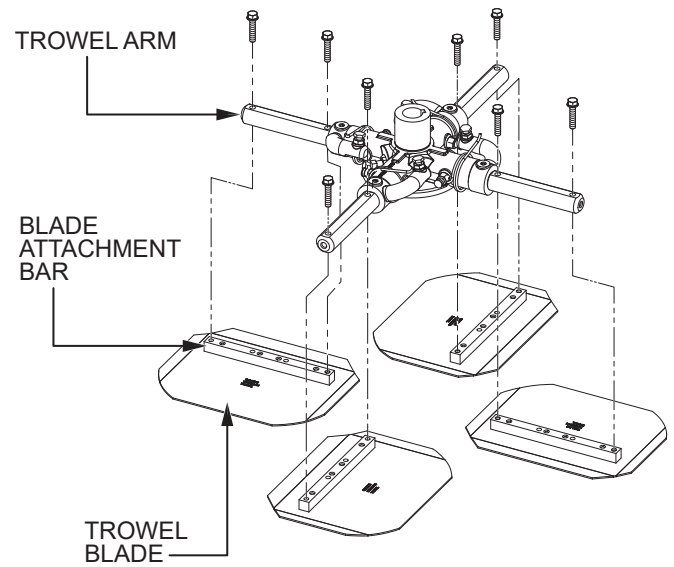

Figure 46. Blade Removal

3. Wire brush and remove all concrete and debris from each of the four trowel arms. This is important to properly seat the new blades.
4. Install the new blades, maintaining the proper blade orientation as noted during removal. Secure with the bolts that were removed earlier.

TROWEL ARM REMOVAL

1. Each trowel arm is held in place at the spider plate by a Zerk grease fitting (hex head bolt). Remove the Zerk grease fitting and the roll pin from the spider plate (Figure 47).

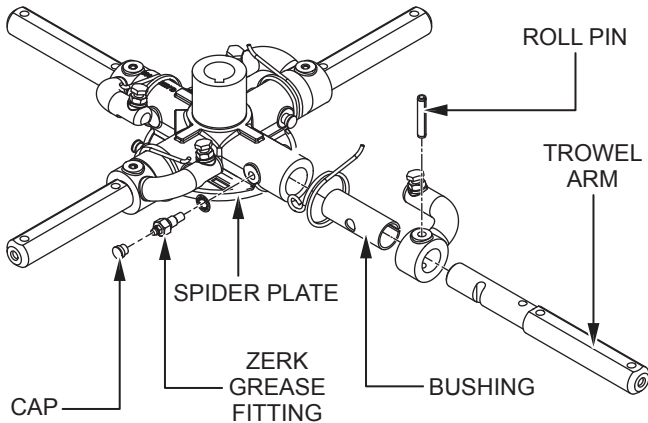

Figure 47. Trowel Arm Removal

2. Remove the trowel arm from the spider plate (Figure 47).
3. Carefully remove the trowel arm bushing (Figure 47).
4. Examine the trowel arm bushing, and clean it if necessary. Replace the bushing if it is worn or out-of-round.

TROWEL ARM INSPECTION

Trowel arms can be damaged by rough handling such as dropping the trowel on a pad or by striking exposed plumbing, forms or rebar while in operation. A bent trowel arm will prevent smooth, fluid rotation of the blades. If bent trowel arms are suspected, examine them for straightness as follows:

1. Place the trowel arm onto a thick steel plate, granite slab, or any other surface which is flat and true (Figure 48).

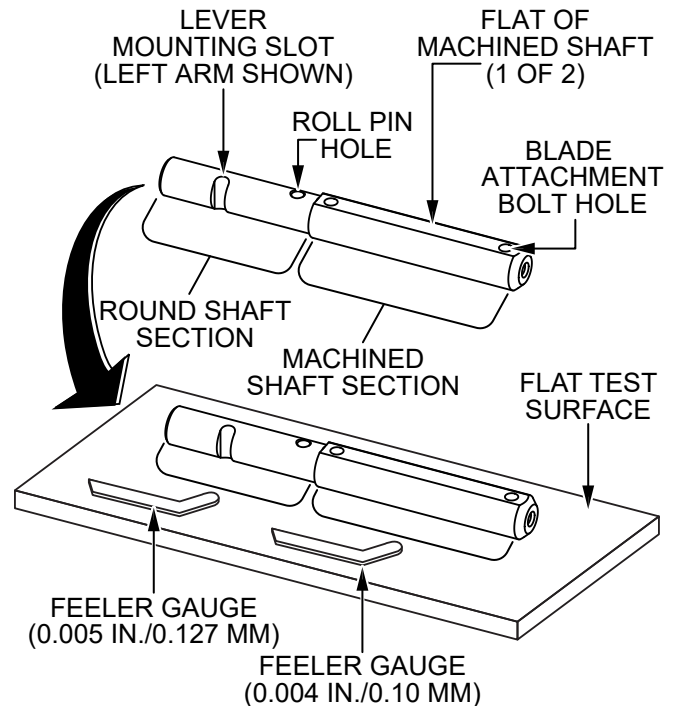

Figure 48. Checking Trowel Arm Straightness

2. Check each flat (2 total) of the machined shaft section of the trowel arm (Figure 48). A feeler gauge of .004 in. (0.10 mm) should not pass between the flat of the trowel arm and the test surface along its length on the test surface.
3. Check the clearance between the round shaft and the test surface as one of the flat sections of the arm rests on the test surface (Figure 48). Rotate the arm to each of the flat sections and check the clearance of the round shaft. Use a feeler gauge of .005 in. (0.127 mm). Each section should have the same clearance between the round of the trowel arm shaft and the test surface.
4. Replace the trowel arm if it is bent or uneven.

Trowel Arm Adjustment

Figure 49 illustrates a **trowel arm adjustment tool**. As a trowel arm is locked into the adjustment tool, the trowel arm bolt is adjusted to where it contacts a stop on the fixture. This will consistently adjust all of the trowel arms, keeping the finisher as flat and evenly pitched as possible.

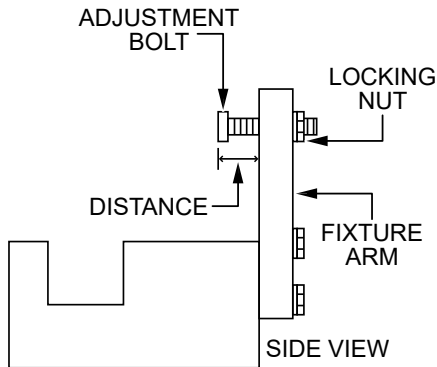

Figure 49. Trowel Arm Adjustment Tool (Side View)

1. Locate a trowel arm adjustment tool (P/N 9177).
2. Place the fixture arm in the correct position (up or down) for the trowel arm's direction of rotation. For trowel arms that rotate **clockwise**, place the fixture arm in the **UP** position (Figure 50A). For trowel arms that rotate **counterclockwise**, place the fixture arm in the **DOWN** position (Figure 50B).

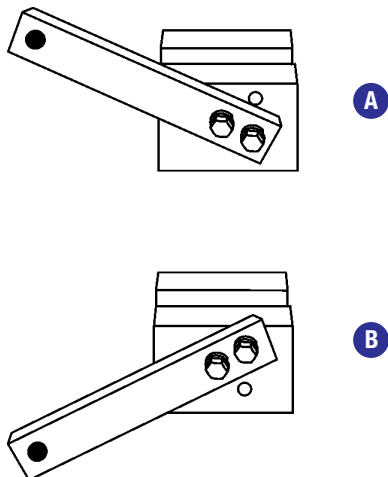

Figure 50. Fixture Arm Position

3. Adjust the fixture adjustment bolt distance shown in Figure 49 to 0.15 in. (3.81 mm).

4. Unscrew the locking bolts on the adjustment tool and place the trowel arm into the fixture channel as shown in Figure 51. A thin shim may be required to cover the blade holes on the trowel arm. Make sure to align the trowel arm adjustment bolt with the fixture adjustment bolt.

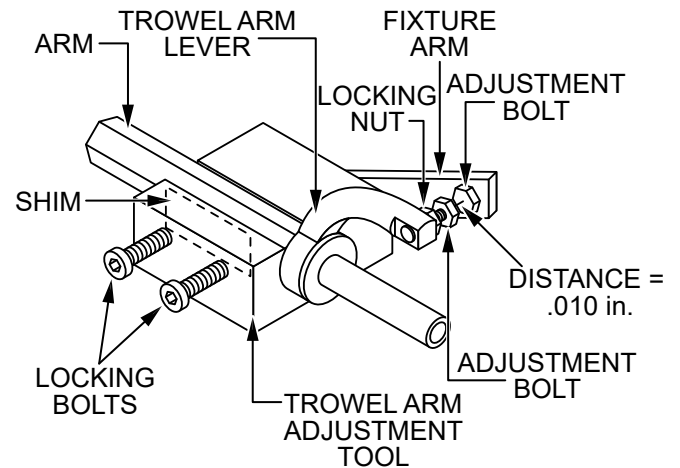

Figure 51. Trowel Arm Adjustment

5. Tighten the locking bolts (Figure 51) with an Allen wrench to secure the trowel arm in place.
6. Loosen the locking nut on the trowel arm lever (Figure 51), then turn the trowel arm adjustment bolt until it barely touches (.010") the fixture adjustment bolt.
7. Once the adjustment has been made, tighten the locking nut on the trowel arm lever to lock it in place.
8. Loosen the locking bolts and remove the trowel arm.
9. Repeat steps 2–8 for the remaining trowel arms.

Reassembly

1. Clean and examine the entire spider assembly including the upper and lower wear plates and thrust collar. Wire brush any concrete or rust buildup. Replace any spider components that are damaged or out-of-round.
2. Make sure the bronze trowel arm bushings are not damaged or out-of-round. Clean the bushings if necessary. Replace any bronze bushing that is damaged or worn.
3. Reinstall the bronze bushings onto the trowel arm.
4. Repeat steps 2–3 for each trowel arm.
5. Make sure that the spring tensioner is in the correct position to exert tension on the trowel arm.
6. Insert all trowel arms with levers (with bronze bushings already installed) into the spider plate, using care to align the grease holes on the bronze bushings with the grease hole fittings on the spider plate.
7. Lock the trowel arms in place by tightening the hex head bolts with Zerk grease fittings and jam nuts.
8. Reinstall the blades onto the trowel arms.
9. Reinstall the stabilizer struts onto the spider assembly.
10. Lubricate all grease points (Zerk fittings) with premium Lithium 12-based grease, conforming to NLG1 Grade #2 consistency.

PREPARATION FOR LONG-TERM STORAGE

1. Disconnect and remove the battery.
2. Drain all fuel from the fuel tank.
3. Clean the trowel exterior with a cloth soaked in clean oil.
4. Cover the trowel with a plastic sheet and store it out of direct sunlight in a moisture- and dust-free location.

TROWEL DECOMMISSIONING

Decommissioning is a controlled process used to safely retire a piece of equipment that is no longer serviceable. If the equipment poses an unacceptable and unrepairable safety risk due to wear or damage, or is no longer cost effective to maintain (beyond life-cycle reliability), and is to be decommissioned (demolition and dismantlement), the following procedure must be performed:

1. Drain all fluids completely. These may include engine oil, gasoline, hydraulic oil, and coolant. Dispose of all fluids properly in accordance with local and governmental regulations. **NEVER** pour fluids on the ground or down drains or sewers.
2. Remove the battery and bring it to an appropriate facility for lead reclamation. Use safety precautions when handling batteries that contain sulfuric acid.
3. The remainder can be brought to a salvage yard or metal reclamation facility for further dismantling.

TROUBLESHOOTING

Trowel Troubleshooting		
Symptom	Possible Problem	Solution
Seat switch not functioning.	Other problems?	Check seat function with a multimeter.
	Loose wire connections?	Check wiring. Replace as necessary.
	Bad contacts?	Replace seat cushion (contains the switch).
If trowel bounces, rolls concrete, or makes uneven swirls in concrete.	Blades?	Make certain blades are in good condition, not excessively worn. Finish blades should measure no less than 2" (50 mm) from the blade bar to the trailing edge, combo blades should measure no less than 3.5" (89 mm). Trailing edge of blade should be straight and parallel to the blade bar.
	Spider?	Check that all blades are set at the same pitch angle as measured at the spider. A field adjustment tool is available for height adjustment of the trowel arms.
	Bent trowel arms?	Check the spider assembly for bent trowel arms. If one of the arms is even slightly bent, replace it immediately.
	Trowel arm bushings?	Check the trowel arm bushings for tightness by moving the trowel arms up and down. If there is more than 1/8" (3.2 mm) of travel at the tip of the arm, the bushings should be replaced. All bushings should be replaced at the same time.
	Thrust collar?	Check the flatness of the thrust collar by rotating it on the spider. If it varies by more than 0.02" (0.5 mm) replace the thrust collar.
	Thrust collar bushing? Blade torsion spring hanging below blade?	Check the thrust collar by rocking it on the spider. If it can tilt more than 1/16" (1.6 mm) as measured at the thrust collar O.D., replace the bushing in the thrust collar.
	Thrust bearing worn?	Check the thrust bearing to see that it is spinning freely. Replace if necessary.
	Blade pitch?	Check blades for consistent pitch. Adjust per Maintenance section instructions if necessary.
Machine has a perceptible rolling motion while running.	Spider finger screws?	Adjust per procedure in Maintenance section.
	Yoke?	Check to make sure that both fingers of the yoke press evenly on the wear cap. Replace yoke as necessary.
	Blade pitch?	Check to ensure that each blade is adjusted to have the same pitch as all other blades. Adjust per Maintenance section in manual.

TROUBLESHOOTING

Trowel Troubleshooting (Continued)		
Symptom	Possible Problem	Solution
Lights (optional) not working.	Wiring?	Check all electrical connections, including the master ON/OFF switch and check to see if wiring is in good condition with no shorts. Replace as necessary.
	Lights?	Check to see if light bulbs are still good. Replace if broken.
Retardant spray (optional) not working.	Retardant?	Check retardant level in tank. Fill tank as required.
	Wiring?	Check all electrical connections, including the master ON/OFF switch connections. Replace components and wiring as necessary.
	Bad switch?	Check the continuity of the master ON/OFF switch. Replace if broken.
	Bad spray pump?	If pump has a voltage present when the switch is turned on but does not operate, and electrical connections to the pump are good, replace the pump.
Steering is unresponsive.	Bad fuse?	Check fuse. Replace fuse if defective.
	Worn components?	Check for wear of steering bearings and linkage components. Replace if necessary.
	Pivots?	Check to ensure free movement of hydraulic drive motors.
Pitch system not working.	Hydraulic pressure?	Check to ensure that hydraulic steering pressure is adequate.
	Wiring?	Check and repair wiring and connectors as necessary.
	Actuators?	Check pitch system fuses. Replace if necessary.

TROUBLESHOOTING

Engine Troubleshooting		
Symptom	Possible Problem	Solution
Difficult to start, fuel is available, but no spark at spark plug.	Spark plug bridging?	Check gap, insulation or replace spark plug.
	Carbon deposit on spark plug?	Clean or replace spark plug.
	Short circuit due to deficient spark plug insulation?	Check spark plug insulation, replace if worn.
	Improper spark plug gap?	Set to proper gap.
	Spark plug is red?	Check transistor ignition unit.
	Spark plug is bluish white?	If insufficient compression, repair or replace engine. If injected air leaking, correct leak. If carburetor jets clogged, clean carburetor.
	No spark present at tip of spark plug?	Check transistor ignition unit is broken, and replace defective unit. Check if voltage cord cracked or broken and replace. Check if spark plug is fouled and replace.
	No oil?	Add oil as required.
	Oil pressure alarm lamp blinks upon starting? (if applicable)	Check automatic shutdown circuit, oil sensor. (if applicable)
Difficult to start, fuel is available, and spark is present at the spark plug.	ON/OFF switch is shorted?	Check switch wiring, replace switch.
	Ignition coil defective?	Replace ignition coil.
	Improper spark gap, points dirty?	Set correct spark gap and clean points.
	Condenser insulation worn or short circuiting?	Replace condenser.
	Spark plug wire broken or short circuiting?	Replace defective spark plug wiring.
Difficult to start, fuel is available, spark is present and compression is normal.	Wrong fuel type?	Flush fuel system, replace with correct type of fuel.
	Water or dust in fuel system?	Flush fuel system.
	Air cleaner dirty?	Replace air cleaner.
Difficult to start, fuel is available, spark is present and compression is low.	Suction/exhaust valve stuck or protruded?	Reseat valves.
	Piston ring and/or cylinder worn?	Replace piston rings and/or piston.
	Cylinder head and/or spark plug not tightened properly?	Torque cylinder head bolts and spark plug.
	Head gasket and/or spark plug gasket damaged?	Replace head and spark plug gaskets.

ELECTRICAL COMPONENT LOCATOR

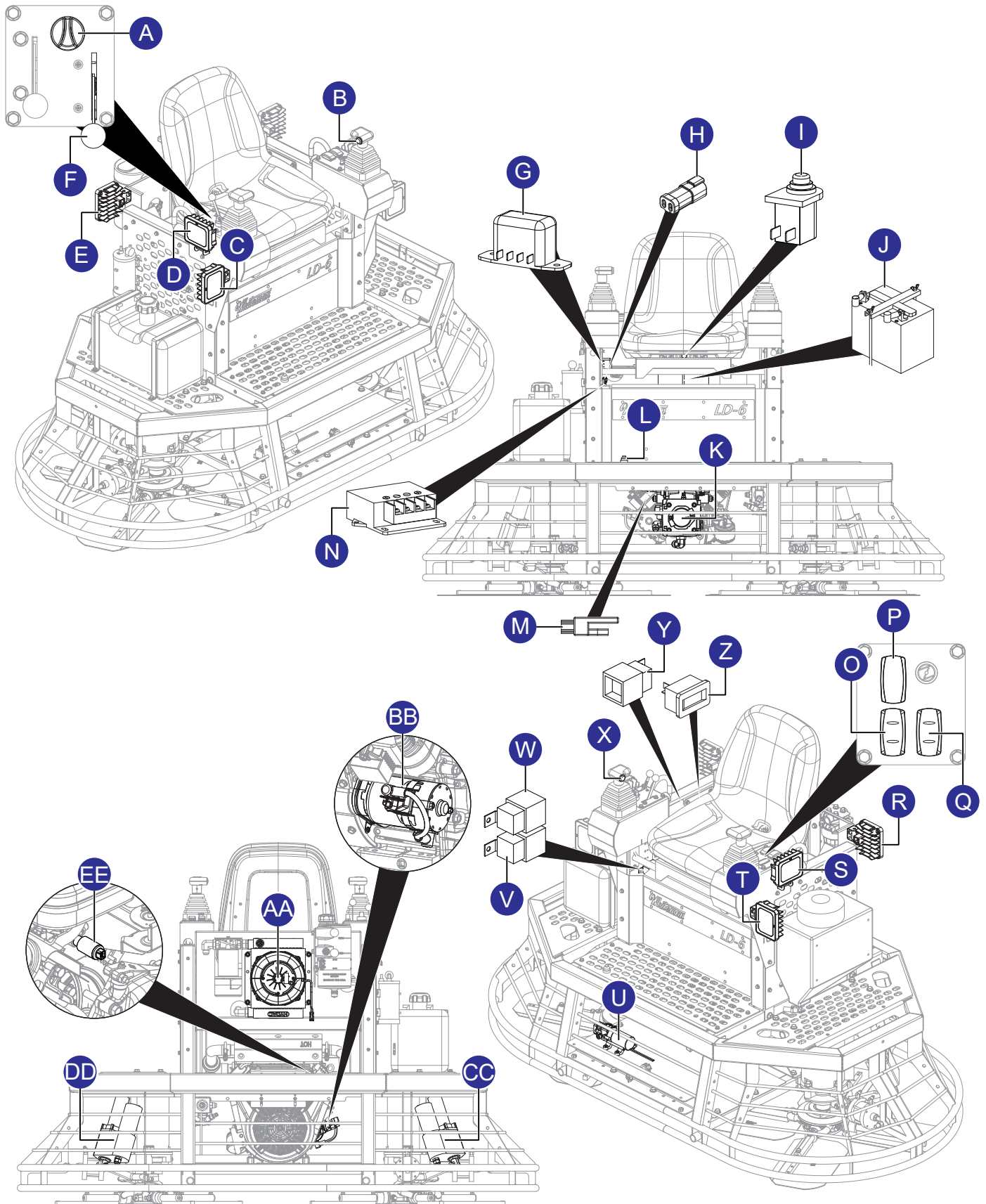

ELECTRICAL WIRING DIAGRAM

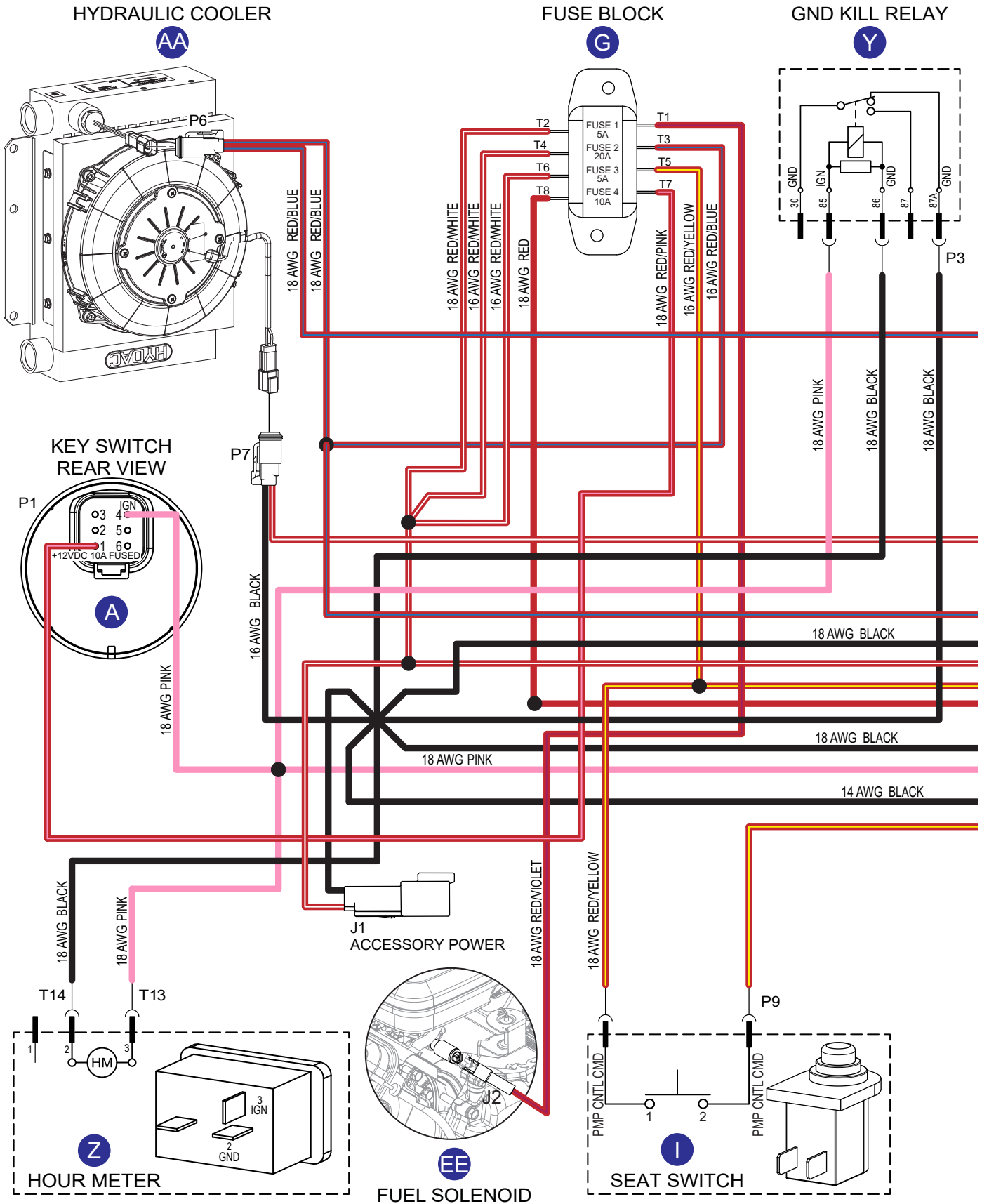

ELECTRICAL WIRING DIAGRAM

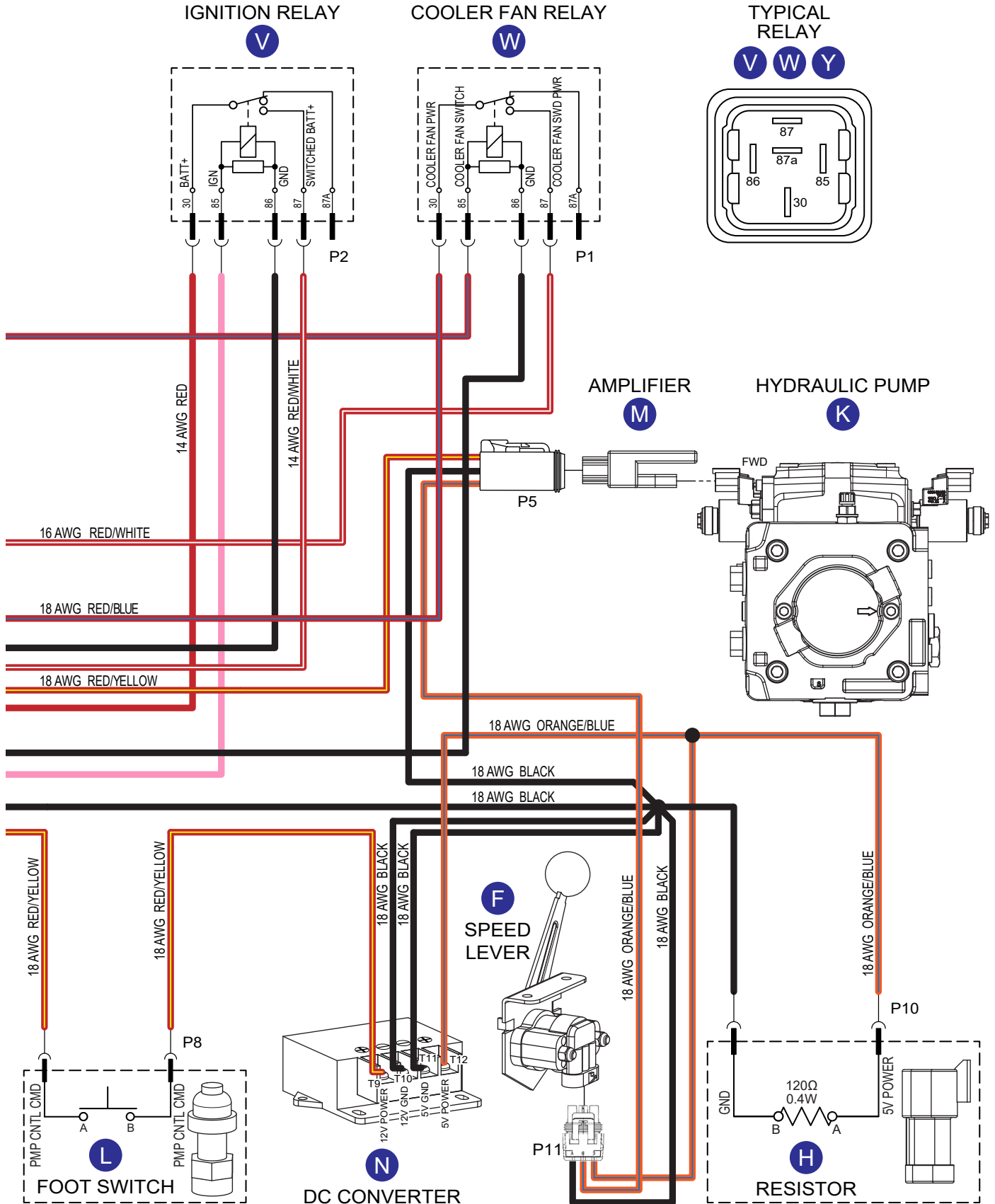

ELECTRICAL WIRING DIAGRAM (PITCH KIT)

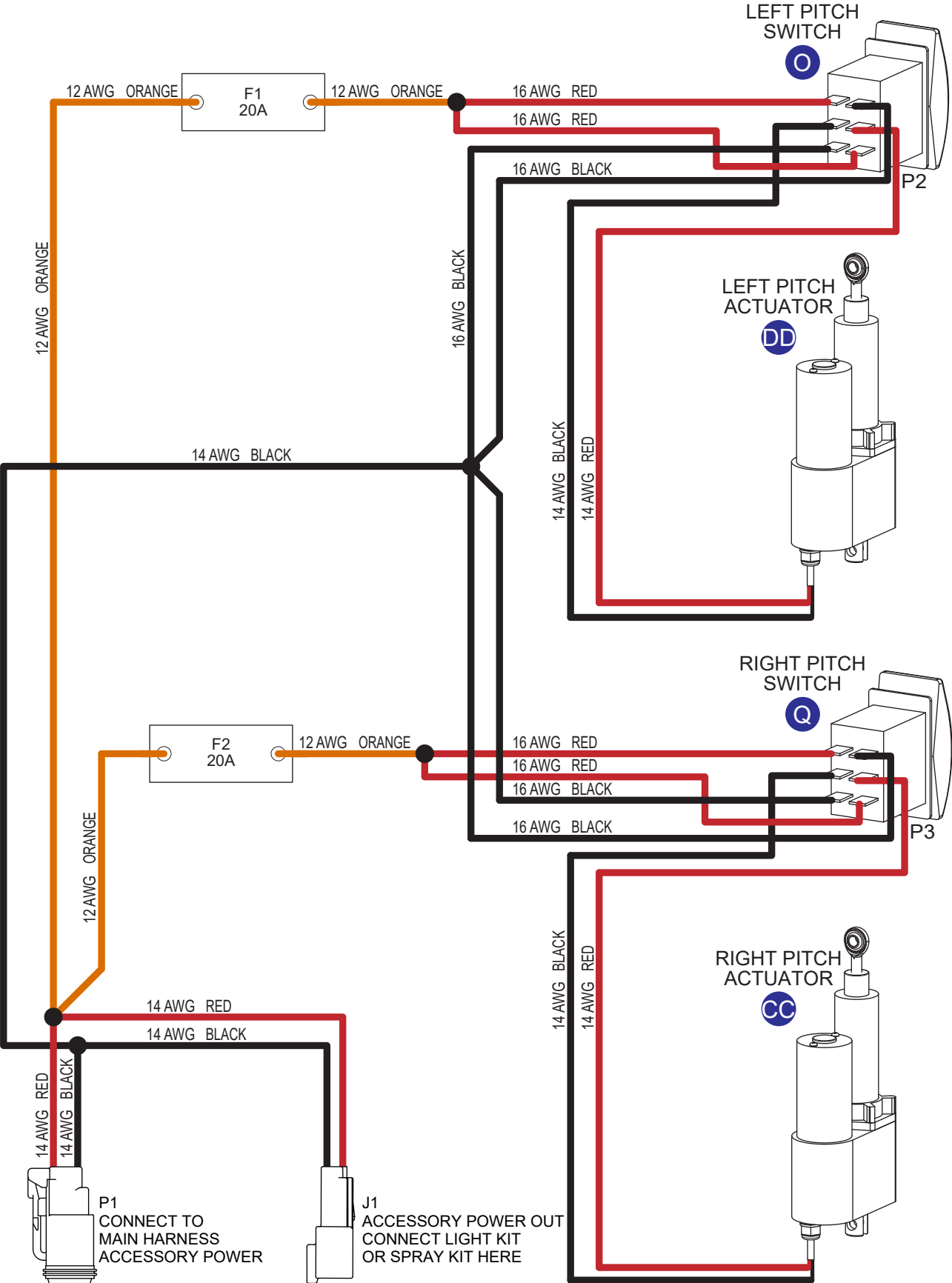

ELECTRICAL WIRING DIAGRAM (OPTIONAL LIGHT KIT)

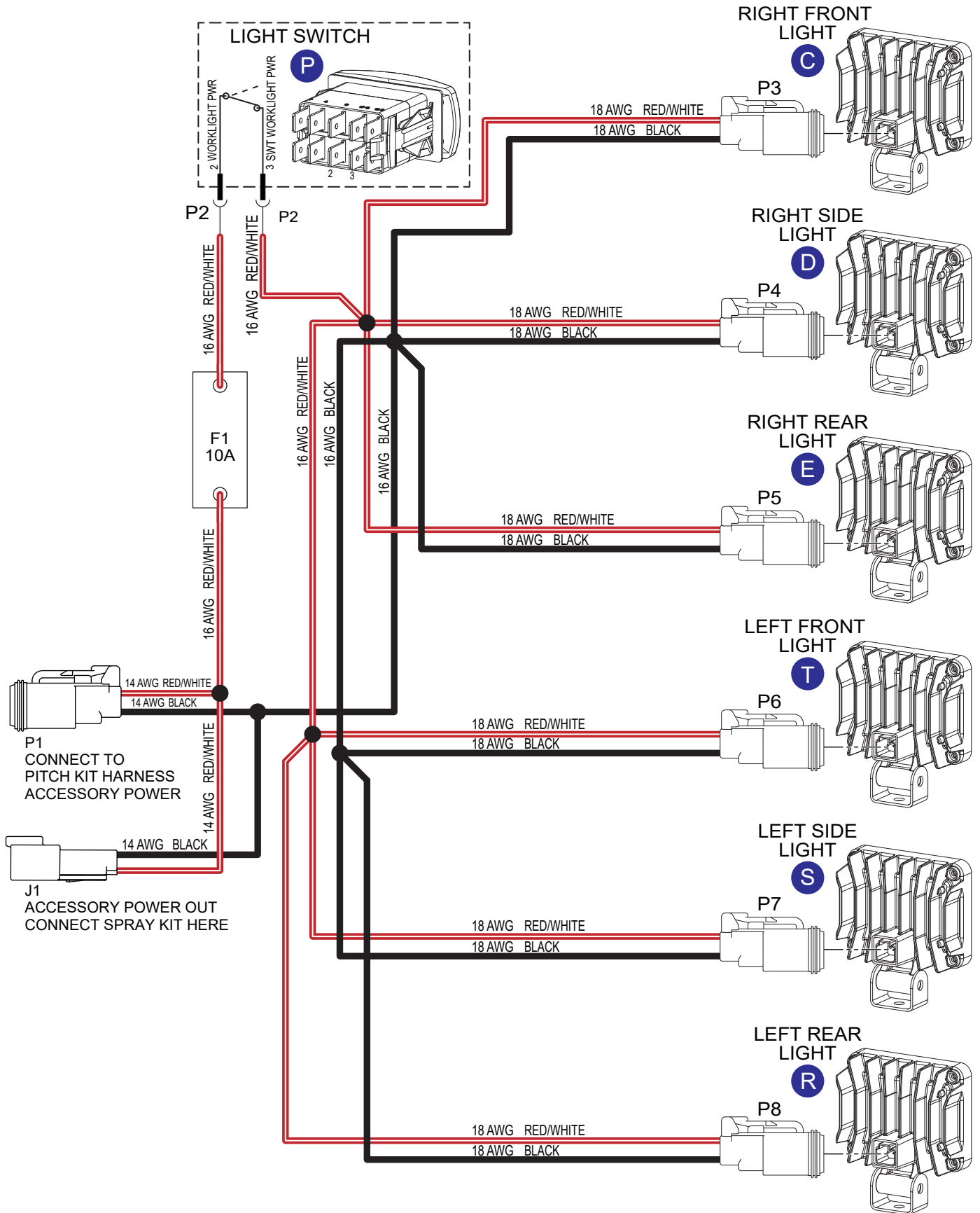

ELECTRICAL WIRING DIAGRAM (OPTIONAL SPRAY KIT)

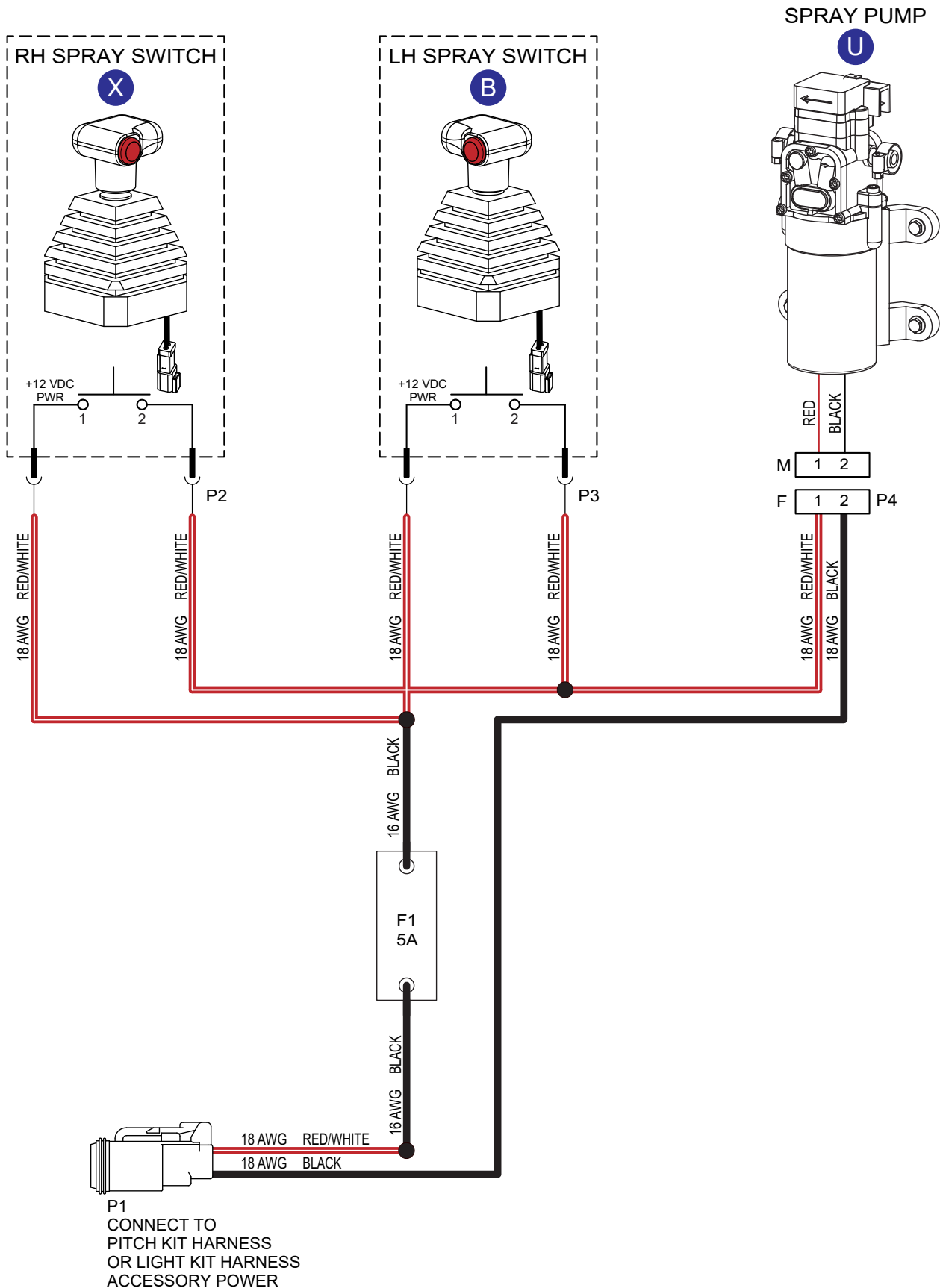

ELECTRICAL WIRING DIAGRAM (POWER AND GROUND)

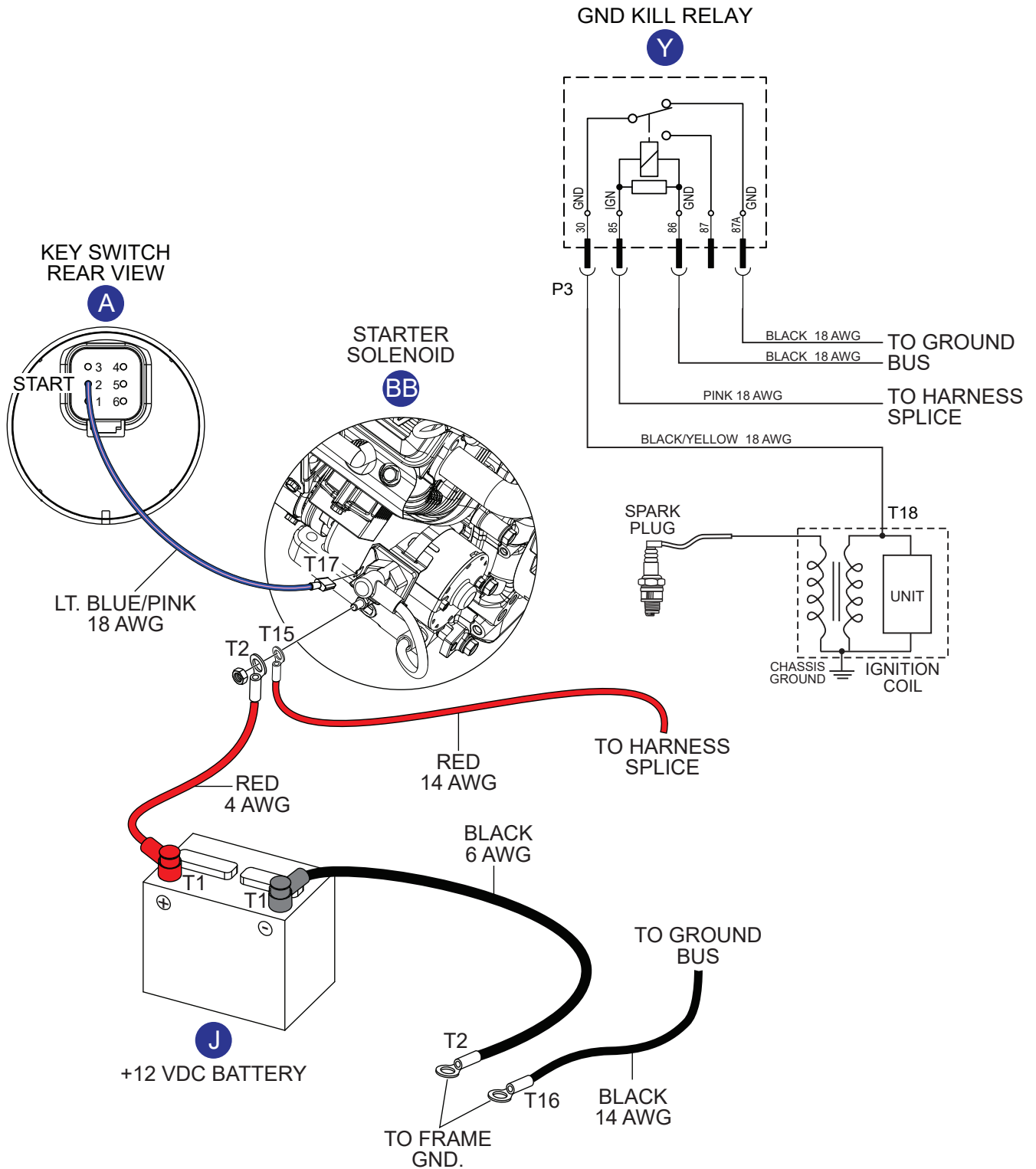

HYDRAULIC COMPONENT LOCATOR

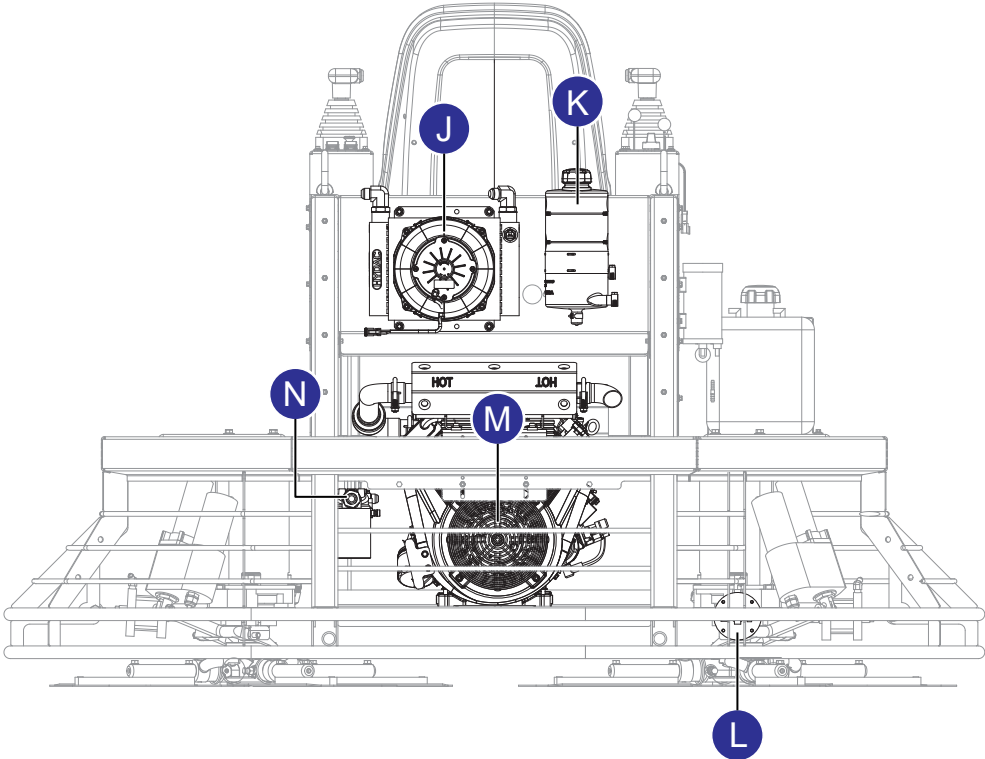
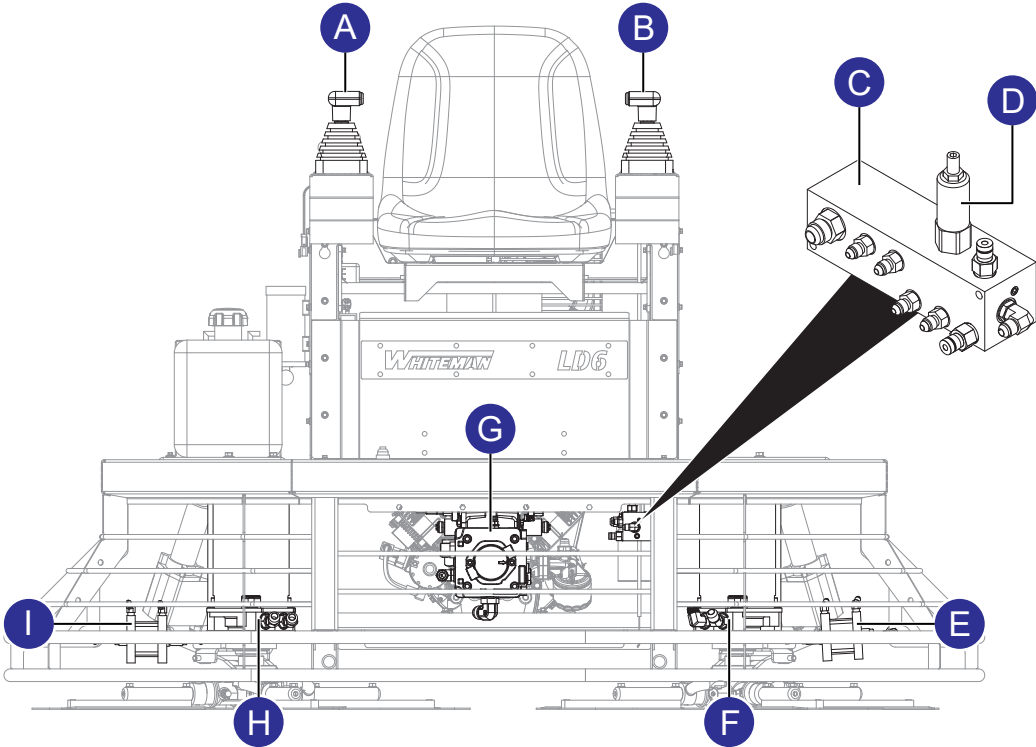

HYDRAULIC SYSTEM DIAGRAM

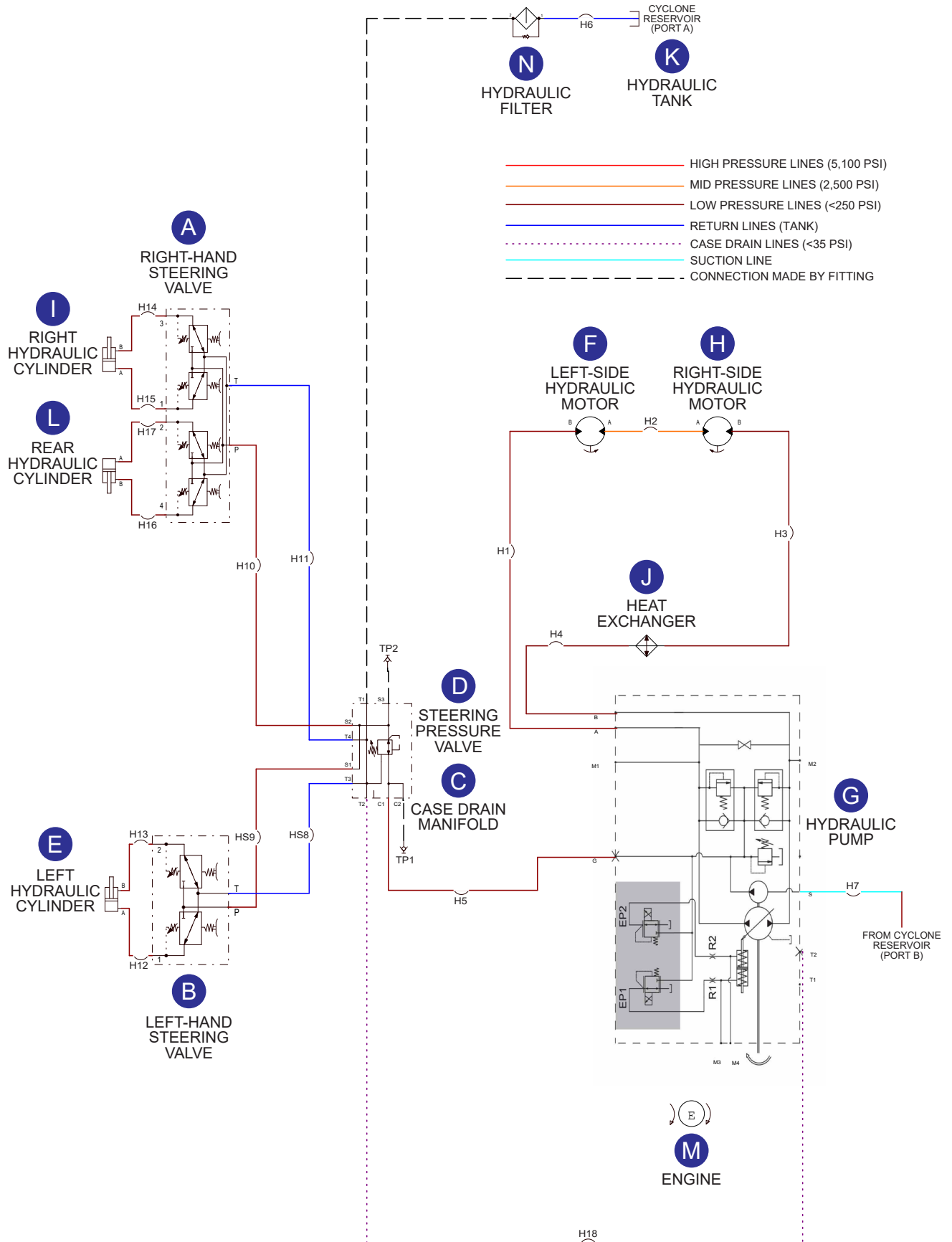

OPERATION MANUAL

HERE'S HOW TO GET HELP

PLEASE HAVE THE MODEL AND SERIAL
NUMBER ON-HAND WHEN CALLING

UNITED STATES

Multiquip Inc.

(310) 537- 3700
6141 Katella Avenue Suite 200
Cypress, CA 90630
E-MAIL: mq@multiquip.com
WEBSITE: www.multiquip.com

CANADA

Multiquip

(450) 625-2244
4110 Industriel Boul.
Laval, Quebec, Canada H7L 6V3
E-MAIL: infocanada@multiquip.com

UNITED KINGDOM

Multiquip (UK) Limited Head Office

0161 339 2223
Unit 2, Northpoint Industrial Estate,
Globe Lane,
Dukinfield, Cheshire SK16 4UJ
E-MAIL: sales@multiquip.co.uk

© COPYRIGHT 2023, MULTIQUIP INC.

Multiquip Inc, the MQ logo are registered trademarks of Multiquip Inc. and may not be used, reproduced, or altered without written permission. All other trademarks are the property of their respective owners and used with permission.

This manual MUST accompany the equipment at all times. This manual is considered a permanent part of the equipment and should remain with the unit if resold.

The information and specifications included in this publication were in effect at the time of approval for printing. Illustrations, descriptions, references and technical data contained in this manual are for guidance only and may not be considered as binding. Multiquip Inc. reserves the right to discontinue or change specifications, design or the information published in this publication at any time without notice and without incurring any obligations.



PN: 45640